

S23

UNIVERSAL CYLINDRICAL GRINDING MACHINE

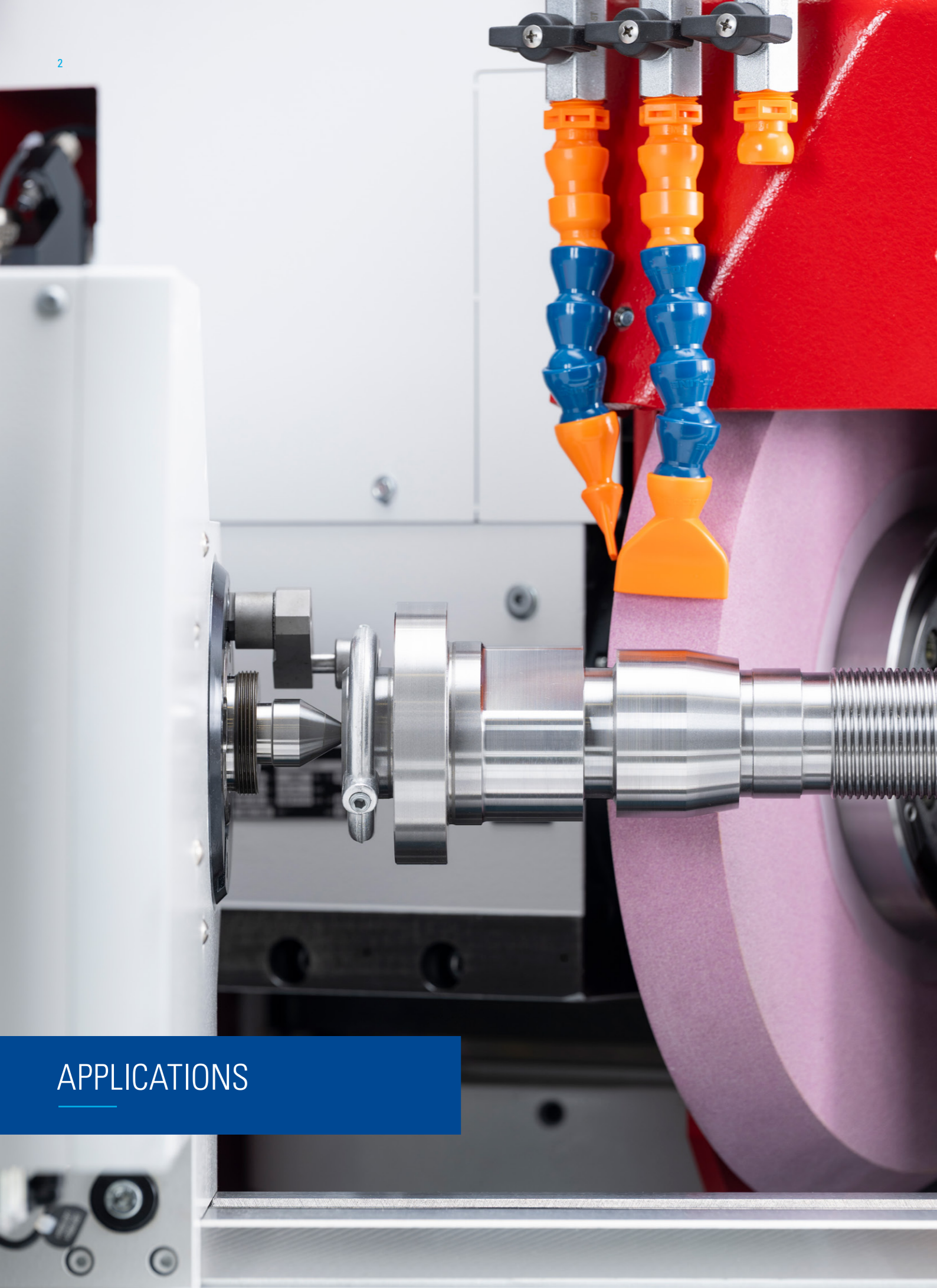



APPLICATIONS

STUDER S23 IN USE

Compact in design, versatile in use, and intuitive to operate – the S23 universal cylindrical grinding machine impresses with outstanding precision and maximum productivity.

Offering excellent value, it is the ideal choice – equally suited to flexible one-off production in small workshops and efficient high-volume production in large-scale operations.



S23

DIMENSIONS

- Center distance 650/1000 mm (25.6/39.4")
- Center height 175 mm (6.9")
- Max. workpiece weight 120 kg (264 lbs)
- Overall weight from 4450 kg (9790 lbs)

HARDWARE

- Selectable wheelhead:
 - Fixed wheelhead, adjustable 0°/15°/30°
 - Universal wheelhead, Hirth 2.5°, manual
 - Universal wheelhead, Hirth 1°, automatic
 - Up to three grinding tools selectable
 - Frequency-controlled belt-driven or motor spindles available
- External and internal grinding possible in one setup
- C-axis for out-of-round and thread grinding
- Fixed table or swiveling table (up to 8.5°)
- Portable control unit for setup close to the grinding process
- Automatic operating door
- Granitan® S103 mineral-cast machine base

SOFTWARE

- C.O.R.E. OS operating system
- Very simple programming thanks to StuderPictogramming
- Reduced set-up and resetting times with STUDER QuickSet
- Standardized interfaces for loader and peripheral devices
- Flexibly upgradeable with integrated software modules
- StuderWIN programming software (optional) for creating grinding and dressing programs on an external PC

YOUR BENEFIT

- Modern cooling thanks to EcoJet™
- Maximum precision due to perfect interplay between hardware and software
- Intuitive, user-friendly, and efficient operation
- Access to important information directly at the panel (e.g., production progress, job details etc.)
- Reduced programming effort for data exchange between C.O.R.E. machines
- Use of Digital Solutions products directly at the machine
- Fast support thanks to direct interaction with our Customer Care team at the machine
- Targeted measures to reduce energy consumption



«The universal solution for every production.»

C.O.R.E. – CUSTOMER ORIENTED REVOLUTION

With C.O.R.E., we make your production fit for the digital future.

The C.O.R.E. system from UNITED GRINDING is a future-oriented hardware and software platform that takes the operation, networking and digitalization of machine tools to a new level.

C.O.R.E. was developed to make our machines and your production environment fit for the digital industry of tomorrow. Operation is simple and intuitive via the multi-touch display, with a modern and customizable

user interface. Thanks to the standardized hardware and software architecture, all UNITED GRINDING machines equipped with C.O.R.E. technology are network-compatible and can be easily integrated into digital factories. All common interface formats are supported. C.O.R.E.'s modern IoT technology core also enables data-based value-added services and integration and communication with cloud-based customer platforms.

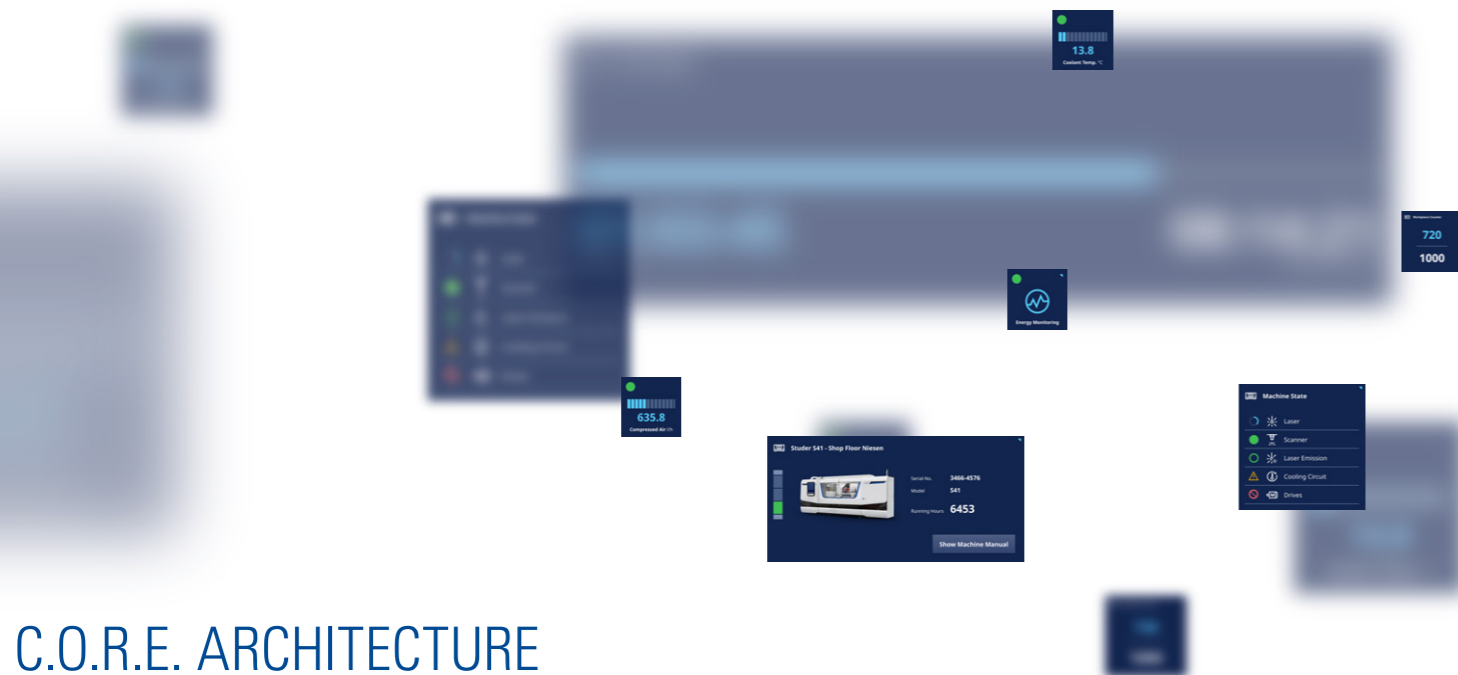

C.O.R.E. ARCHITECTURE

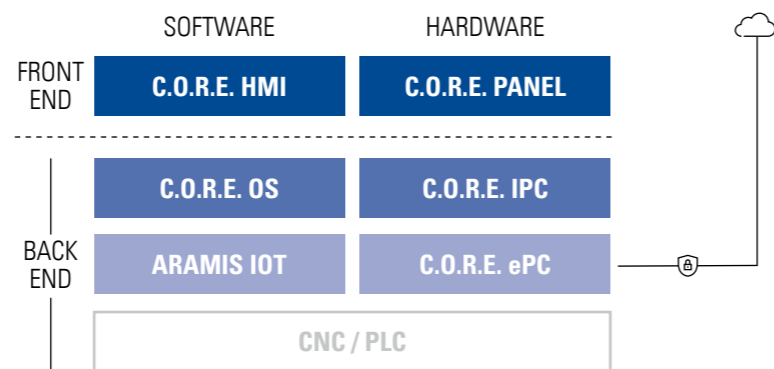

C.O.R.E. PANEL & HMI – NEXT-GENERATION MACHINE OPERATION

Like a large smartphone

With C.O.R.E., UNITED GRINDING has redefined the interaction between man and machine tool. Modern design combined with the most advanced technology to meet the operator requirements of tomorrow. The 24" multi-touch display enables navigation by touch and swipe gestures, similar to a smartphone. The uniform HMI for all UNITED GRINDING machines facilitates set-up, operation and general maintenance. Customizable user roles enable the display and restriction to role-relevant information and thus increase user-friendliness and safety. With the integrated front camera on the panel, assistance can be provided directly at the machine via Remote Service.

Future-proof

The digital capabilities of your machine with C.O.R.E. technology continue to grow. The C.O.R.E. HMI is continuously being expanded with new functionalities, widgets and apps to make it even more user-friendly and personalizable. The arrangement, type and size of the tiles on the HMI can be customized so that every machine operator always has the information that is important to him or her at a glance.

In future, new software updates and functionalities will be easy to install via the customer portal, so you will always be up to date.



Technical data

- 24" Full HD multi-touch display
- Override rotary switch with cycle start
- Standardized function keys
- Integrated 2-hand start
- Electronic key system (RFID)
- Integrated front camera
- Tilt adjustment

USER INTERFACE

StuderWIN

The user interface StuderWIN creates a stable programming environment and contributes to efficient use of the machine. The possibility of fully integrating the measuring system and sensor technology for process monitoring as well as contact detection and balancing systems in the user interface enables standardized programming of the different systems. The software of an optional loading system is also integrated. The drive elements are optimally matched to the control system.

The sophisticated mechanical engineering concept of the S23 is complemented by grinding software developed in-house by STUDER and continuously optimized in collaboration with users of the software. This software offers:

- **StuderPictogramming:** The operator strings the individual grinding cycles together.
- Integrated operating instructions assist safe machine operation.
- The software options for the grinding technology calculations, optimized dressing as well as the contour, thread and out-of-round grinding cycles increase the functionality of the machine.
- **InOne Grind:** The cylindrical grinding cycle can be programmed specifically for the individual grinding task via the clear menu.
- The profiling dialog supports the dressing and reprofiling of the grinding wheel. This includes calculating the optimal number of dressing strokes and providing a graphical display of the dressing paths.

- **Workpiece-oriented programming:** Grinding cycles are aligned with the workpiece geometry and visualized through animation. The workpiece geometry can be created in the integrated editor or imported as a DXF file.
- **InOne Dress:** The easy-to-use dressing cycle supports the machine operator with all dressing tasks.

StuderTechnology Integrated – more than 113 years of expertise

StuderTechnology Integrated drastically simplifies the operation of cylindrical grinding machines. Component quality, machining time, energy efficiency – in short: every key production factor sees a major benefit. What makes the software unique? Its history! Over 113 years of grinding experience have gone into it. It is a combination of grinding practice, empiricism, and years of expert knowledge. The program contains data from countless grinding tests, during which the best processing strategy was determined in each case for a wide range of components. StuderTechnology Integrated reverts specifically to these values depending on the use case. This integrated grinding knowledge can be further optimized as required by the individual grinding experts and can be stored as a customer-specific production specification. This also enables grinders with little experience to benefit from STUDER expertise.

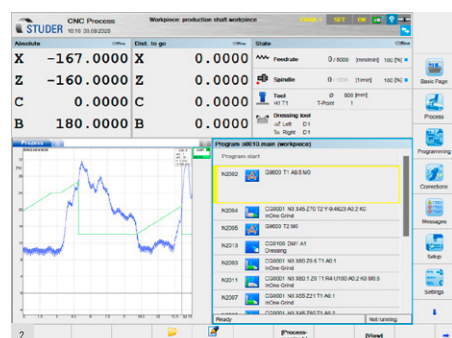
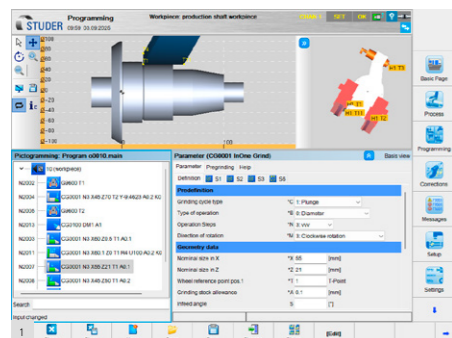

1 InOne Grind programming interface
2 StuderWIN process screen

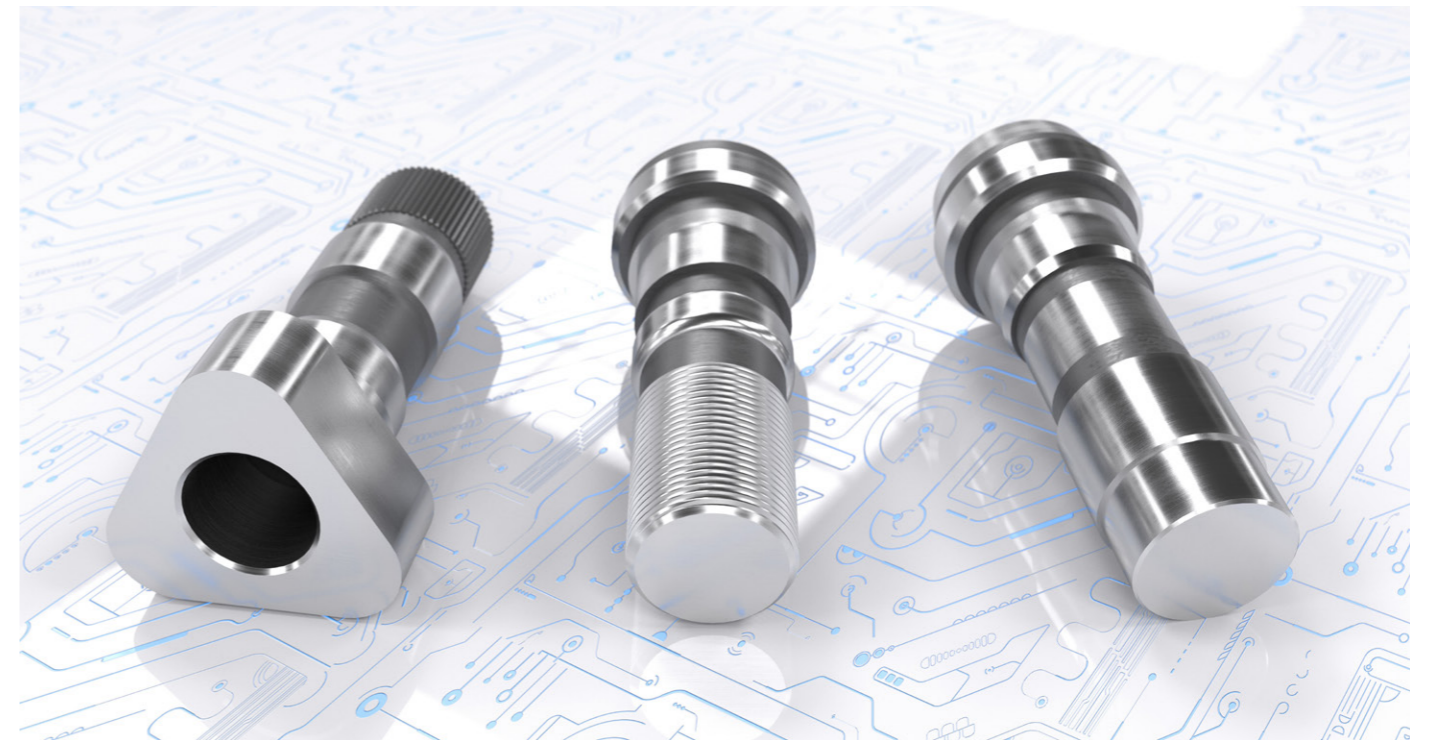

EXPANSION OPTIONS

Expansion packages

The wide range of additional software packages significantly enhances the functionality of STUDER grinding machines.

- **StuderDress Integrated** reduces the profiling time of a grinding wheel by up to 80%.
- **InOne Thread and StuderThread Integrated** deliver full functionality for thread grinding and profiling of thread grinding wheels – capabilities otherwise only possible on a dedicated thread grinding machine.
- **StuderContourBasic Integrated** is ideal for traversing workpiece contours with the grinding wheel in an easy, quick, and safe manner. It includes intuitive contour selection and path simulation.
- **StuderForm Integrated** is the universal out-of-round grinding software for machining polygons, multi-sided parts, and other shapes. Its extensive library of standard shapes makes programming significantly easier.
- **InOne Control**, used in combination with TouchControl, allows control measurements to be carried out with minimal programming effort. InOne Control+ goes a step further by enabling evaluation and documentation of results.
- **StuderTechnology Integrated**
- **InOne Dress+** for specialized functions in dressing.
- **InOne Grind+** for even more advanced requirements in cylindrical grinding cycles.

The S23 meets our customers' highest demands with absolute precision. Thanks to a manageable selection of options, required expansions can be quickly adapted to match the user's needs.

The following options are available:

- Contact detection
- Manual balancing
- «Micro functions»
- Simple BDE interface
- OPC UA interface umati
- Automatically actuated operating door
- B3 I/O loader interface
- PROFINET loader interface
- Digital solutions
- External programming station



GRANITAN® S103 MINERAL-CAST MACHINE BASE

The material structure developed by STUDER on the basis of the company's own formula, which has proved its worth over many years, is produced in a plant using the most modern industrial techniques. The excellent damping properties of the machine base ensure that an outstanding surface quality is achieved in the ground workpieces. The service life of the grinding wheel is also increased, leading to reduced downtimes. Temporary temperature fluctuations are largely offset by the favorable thermal behavior of Granitan®. This results in a high level of dimensional accuracy throughout the day. The guide system for the longitudinal and cross slides is molded directly into the machine base and coated with wear-resistant Granitan® S200 surfacing material. The guideways offer the highest possible accuracy through the entire speed range with high load capacity and dampening levels. Thanks to the robust and low-maintenance design, these excellent guideway properties remain virtually unchanged over time.

- More sustainable production compared to casting
- Vibration-damping
- Thermally stable
- Maximum guideway accuracy

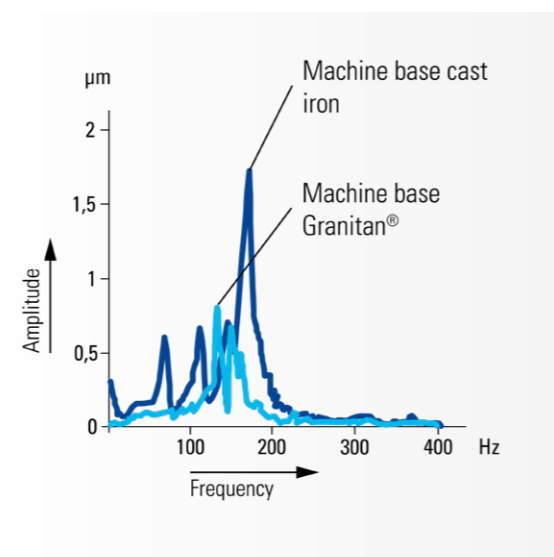

LONGITUDINAL AND CROSS SLIDES

The V and flat guideways for the cross and longitudinal slides with patented surface structure guarantee excellent accuracy and thus enable high cylindricity across the entire workpiece, for example.

The slides are advanced by ball screws connected to a three-phase servo motor via torsion-resistant couplings.



- High geometrical traverse precision
- Auxiliary scale on the longitudinal slide for setup and resetting
- Effective protection of guideways

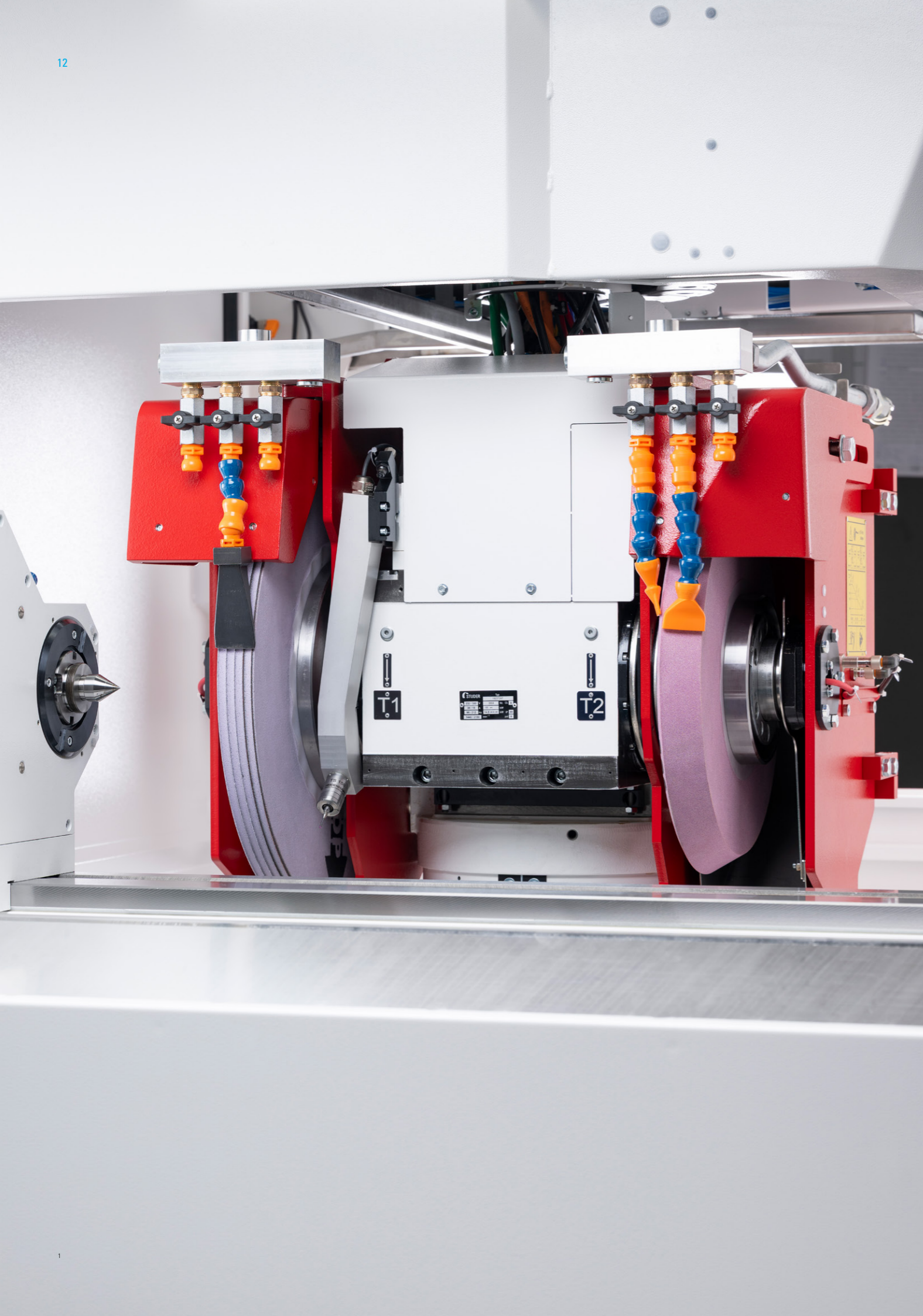

WHEELHEAD

The wheelhead is highly modular, accommodating from one up to three wheels (2 external and 1 internal). Available configurations include a fixed wheelhead (0°/15°/30°) or a swiveling wheelhead – manual 2.5° or automatic 1° (Hirth serration). Both external and internal grinding spindles are available with either belt-drive or direct-drive (motor spindle) options.

Grinding wheel size

Diameter 500 mm (20"), width 63 mm (80 F5) / 2.5" (3.15" F5), bore 203 mm (8"). Drive power: up to 11.5 kW (15.4 hp) for the belt-driven spindle and up to 12.5 kW (16.75 hp) for the motor spindle. A maximum cutting speed of 50 m/s (9842 sfpm) enables efficient stock removal in the grinding process. Optionally, a grinding wheel width of up to 110 mm (F5) / 4.35" (F5) is available.

The speed of the belt-driven internal grinding spindle (lifetime grease lubrication) is continuously adjustable. Spindles with speeds of 20 000 and 40 000 rpm are available. For the direct-drive option, multi-range spindles are used with maximum speeds of 42 000, 60 000, and 90 000 rpm.

- Complete machining
- Motor spindles for external and internal grinding
- High power, up to 12.5 kW (16.75 hp)
- Cutting speed of up to 50 m/s (9842 sfpm)
- Grease-lubricated belt-driven internal grinding spindle with continuously adjustable speed
- High-frequency spindle (option)
- Can be equipped with up to three wheels

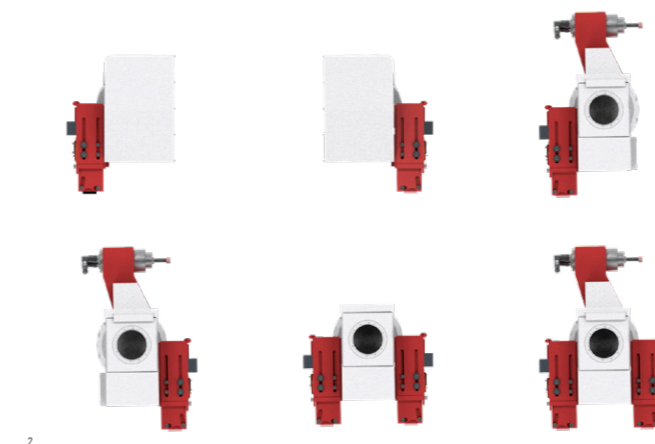

2

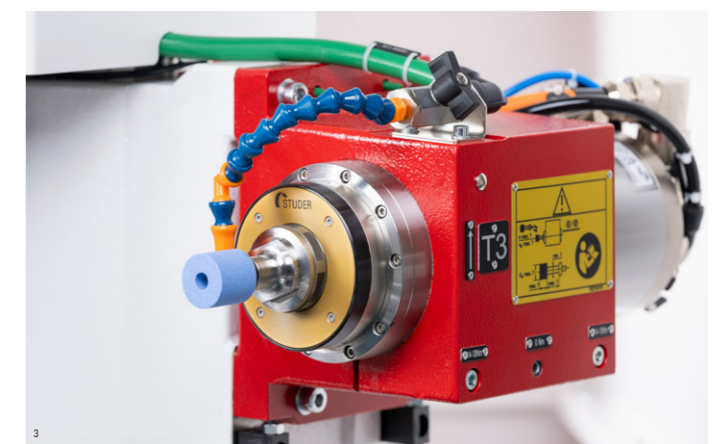

3

- 1 Wheelhead
- 2 Wheelhead variants
- 3 Internal grinding spindle

WORKHEAD

A universal workhead with an MT5 fitting taper or a chuck workhead with an MT4 fitting taper can be used. This makes both live spindle grinding and grinding between centers possible. The workpiece spindles are equipped with roller bearings, are low maintenance, and offer excellent roundness accuracy of under 0.0004 mm / 0.000,016" (optional: 0.0002 mm / 0.000,008"). The fine adjustment allows for cylindricity corrections in the 1 µm (0.000,040") range during live spindle operations. An air cushion lift-off facilitates simple displacement of the workhead during setup and resetting.

- High roundness accuracy
- Large speed range of 1 to max. 1500 rpm
- Cylinder correction (live spindle grinding)
- Air cushion

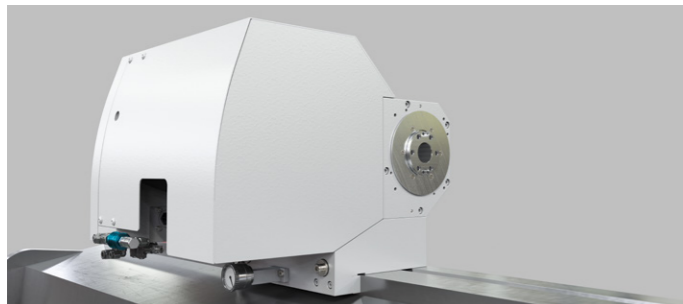
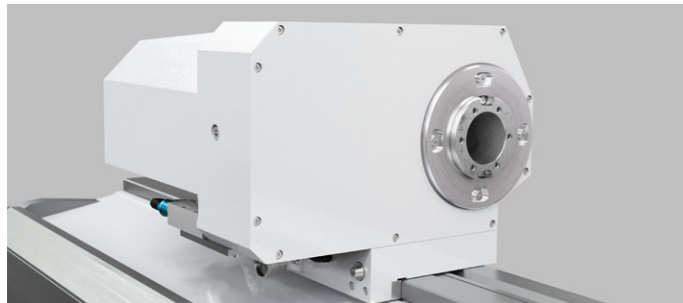
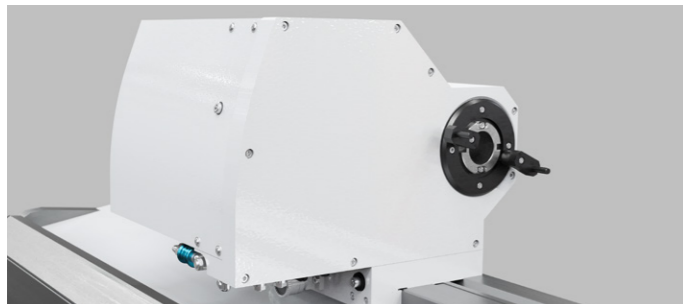

Universal workhead MT5

For external grinding with fixed centers or for live spindle grinding. The spindle is blocked for grinding between fixed centers. C-axis applications are possible with the indirect measuring system.

Universal workhead ISO50

For external grinding with fixed centers or for live spindle grinding. The spindle is blocked for grinding between fixed centers. C-axis applications are possible with the indirect measuring system.

Chuck workhead MT4

For live spindle grinding or external grinding with revolving centers. Thanks to the design, with drive via a rear belt, high loads are possible with live spindle grinding. For high-precision C-axis applications, a measuring system can be installed directly on the spindle.



C AXIS FOR OUT-OF-ROUND AND THREAD GRINDING

Complete machining also entails out-of-round and thread grinding operations to an ever-increasing extent. These processes are made possible by the position- and speed-controlled C-axis. The standard C-axis with a measuring system on the drive motor is also suitable for thread grinding. With their high dynamic rigidity, the axis drives absorb the acceleration and grinding forces without any problem.

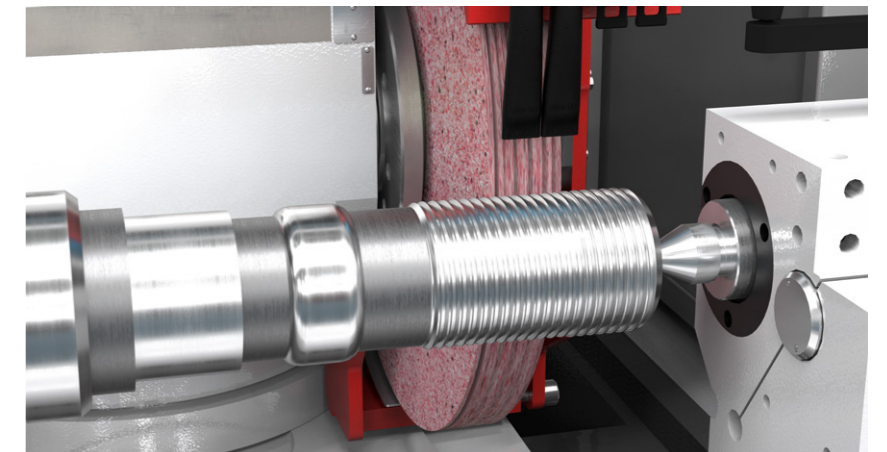

TAILSTOCK

Designed for the use of centers with morse taper 3, the high-precision barrel slides inside the tailstock housing. MT4 is also available as an option. The center pressure can be adjusted with the delicate precision required for grinding high-precision workpieces. The fine adjustment enables taper corrections in the range below $1\ \mu\text{m}$ ($0.000,040''$) when grinding between centers. In order to guarantee optimum thermal stability, the tailstock is flooded with cooling lubricant, as are the barrel and the diamond holder.

- Cylindricity correction
- Thermal stabilization by flooding
- Air cushion
- Integrated park position
- Hydraulic barrel retraction (option)

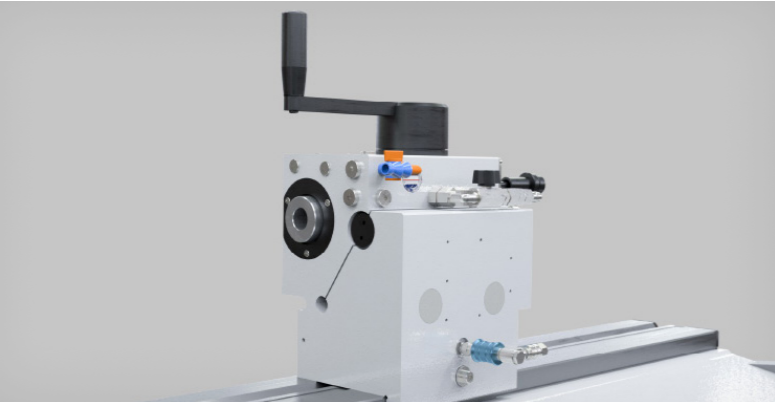

Tailstock MT3

Clamping takes place with the help of a spring. This tailstock is suitable for workpiece weights up to 80 kg (176 lbs).

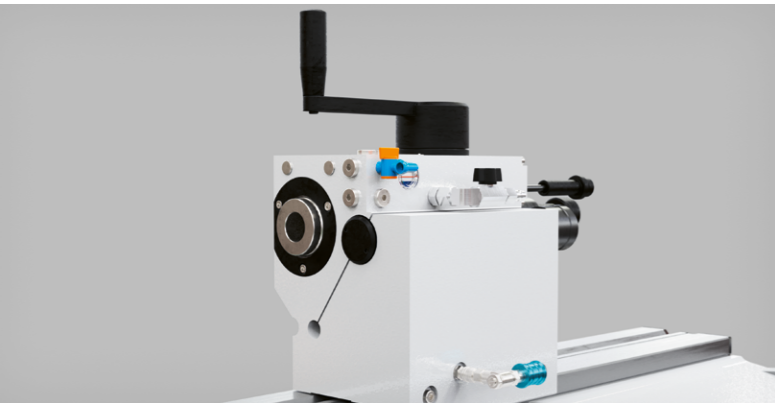

Tailstock MT4

The tailstock offers a barrel stroke of 60 mm (2.36") with a barrel diameter of 50 mm (1.97") and is suitable for workpieces of up to 120 kg (264 lbs).



Fine adjustment for cylindricity corrections

The fine adjustment enables taper corrections in the range below $1\ \mu\text{m}$ ($0.000,040''$) when grinding between centers. This ensures the highest dimensional accuracy and surface quality, without time-consuming reworking.

DRESSING

An easy-cutting grinding wheel is essential for cost-effective and high-quality grinding. STUDER offers a large selection of dressing units, in order to coordinate the dressing process flexibly and optimally with the properties specific to the workpiece, tool or materials. The grinding wheel profile and dressing parameters are easily defined via macros. Another STUDER speciality are the grinding wheel reference

points (T-numbers). This enables programming with nominal dimensions, considerably simplifying the creation of grinding programs.

A software package is available to fine tune the dressing process and includes additional dressing functions.

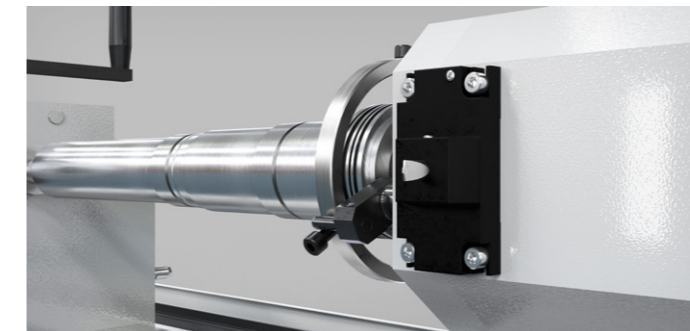

Stationary dressing

The clamping surface is suitable for various fixed dressing tools. The diamond holder can also be optionally attached to the tailstock, workhead, or workpiece table.

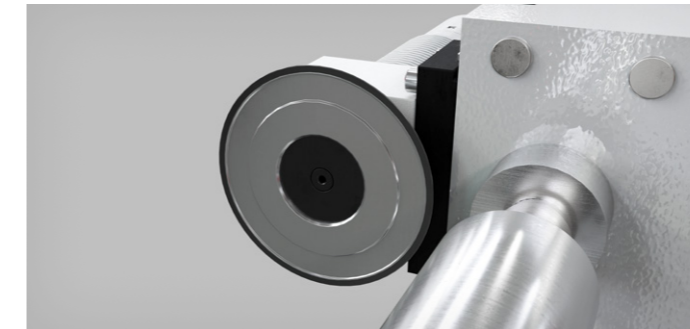

Rotary dressing

Rotating dressing tools are particularly suitable for dressing CBN grinding wheels.



Dressing holder in T-slot with fixed table

With a fixed workpiece table, the dressing holder is ideally secured in the T-slot.



Hydraulically swiveling dressing unit

This unit can be flexibly mounted on the workpiece table, primarily for dressing internal grinding wheels close to the workpiece, minimizing auxiliary times.

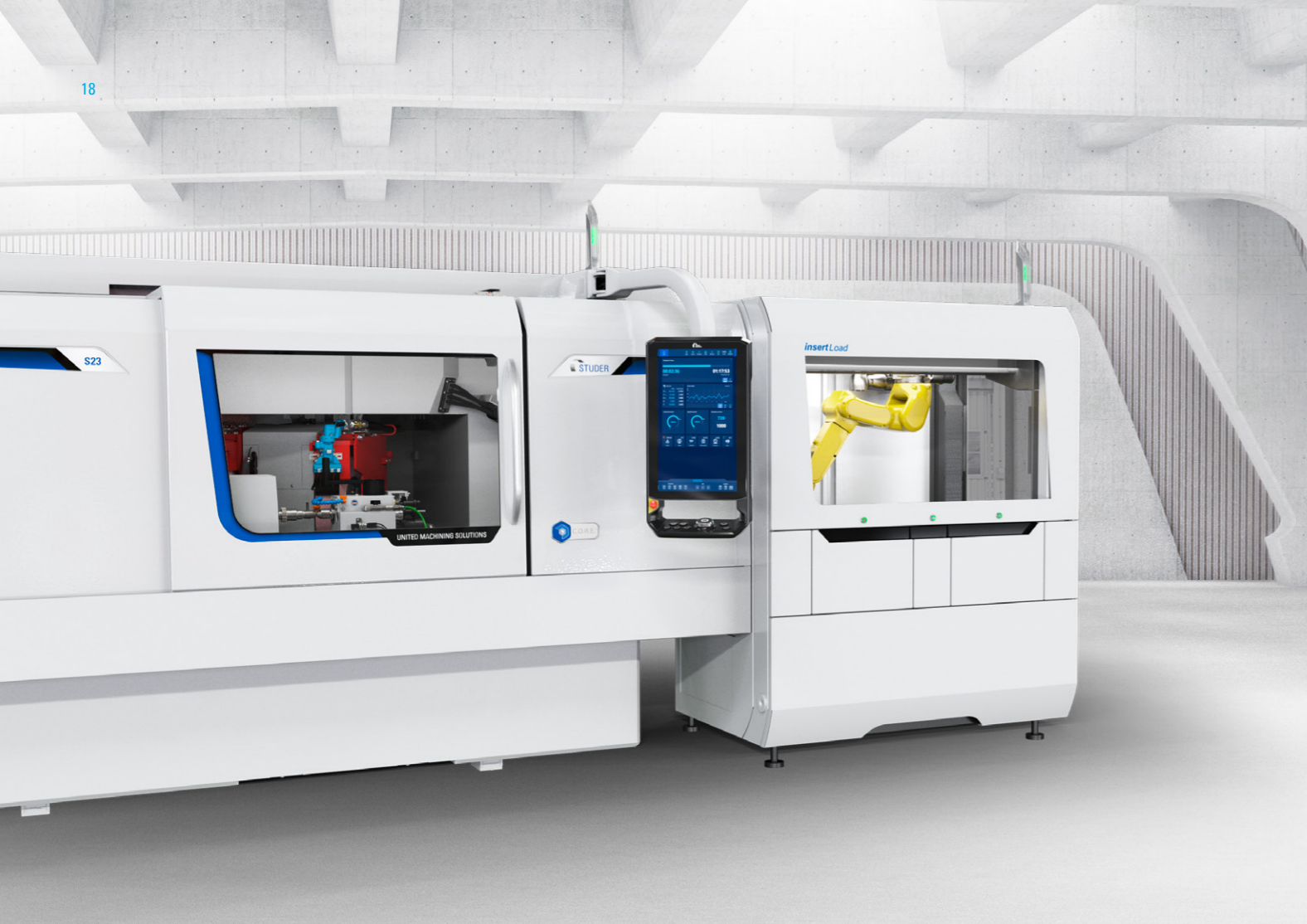

AUTOMATION

Several loading systems are available for the S23. From the cost-effective *easyLoad*, operated via the machine control, to the *insertLoad* with its own control system, all the way to custom solutions with a modular design that can be precisely tailored to the machine application and machining process. The appropriate peripherals ensure seamless integration into the respective production process. The handling systems communicate with the machine via the standardized loader interface and enable even complex handling tasks to be solved. Project-specific components such as pre- and post-measurement stations, brushing and blowing off stations, calibration part repositories etc., can be implemented in the system. Comprehensive quality control is possible during the grinding process. This entails: in-process, post-process, recording, evaluation, and correction. In grinding, especially in match grinding, such quality assurance is crucial.

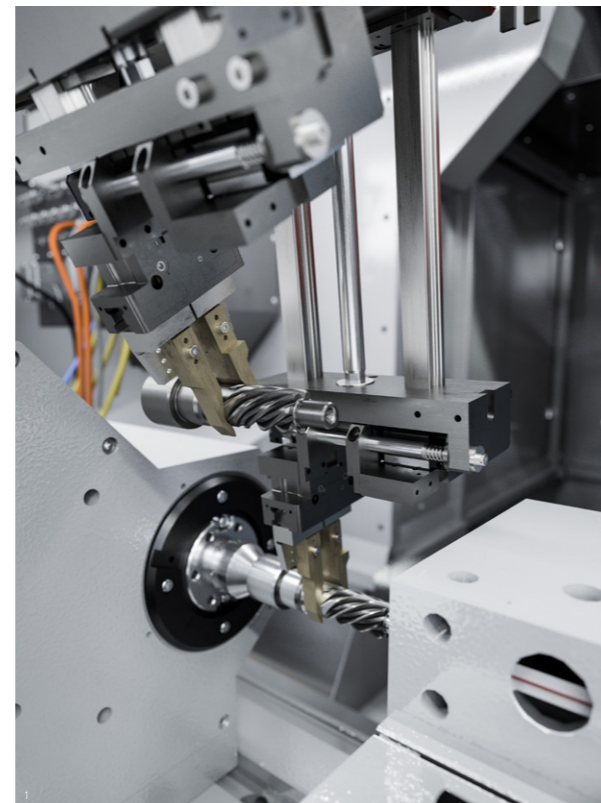

1 STUDER *easyLoad* V-gripper

WE ARE HERE FOR YOU!

Our products are designed to meet customer demands for as long as possible, they are intended to operate efficiently, reliably, and be available at any time.

From «Start up» through to «Retrofit» – our Customer Care is there for you throughout the working life of your machine. For this reason, you can rely on competent Helplines worldwide and Service Engineers near you:

- We will provide you with fast, straight-forward support.
- We will help to increase your productivity.
- We work professionally, reliably and transparently.
- We will provide a professional solution to your problems.



Start up
Commissioning
Warranty extension



Qualification
Training
Product support



Prevention
Maintenance
Inspection



Service
Customer service
Customer consultation
Helpline



Digital Solutions
Remote Service

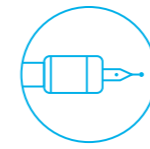

Material
Spare parts
Replacement parts
Accessories



Rebuild
Machine overhaul
Assembly overhaul



Retrofit
Modifications
Retrofits

DIGITAL SOLUTIONS

Digital Solutions stand for products and services that open up the data space of your machine through IoT-based networking, enable seamless integration across the entire store floor in digital value-added networks and provide data-based value-added services

and digital services – for greater efficiency, productivity and competitiveness.

You can find out more about the services of Digital Solutions on our website under the Customer Care section.



CUSTOMER CARE

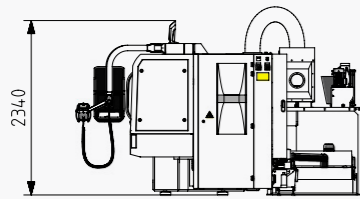
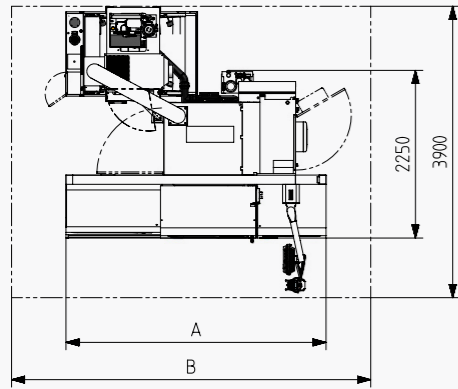

	A	B
Center distance 650 mm / 26"	2 850 mm (112")	4 550 mm (177")
Center distance 1000 mm / 39"	3 500 mm (138")	4 800 mm (189")

TOTAL WEIGHT

Center distance 650 mm / 26"	4 450 to 5 200 kg (9 790 lbs to 11 440 lbs)
Center distance 1000 mm / 39"	5 000 to 5 600 kg (11 000 to 12 320 lbs)

The information given is based on the technical levels of our machine at the time of this brochure going to print. We reserve the right to further develop our machines technically and make design modifications. This means that the dimensions, weights, colors, etc. of the machines supplied can differ. The diverse application possibilities of our machines depend on the technical equipment specifically requested by our customers. The equipment specifically agreed with the customer is therefore exclusively definitive for the equipping of the machines, and not any general data, information or illustrations.

TECHNICAL DATA

MAIN DIMENSIONS

Distance between centers	650 / 1 000 mm (26" / 39.4")
Center height	175 mm (6.9")
Max. workpiece weight between centers	120 kg (264 lbs)

CROSS SLIDE: X AXIS

Max. travel	285 mm (11.2")
Speed	0.01-10 000 mm/min (0.000,4 - 394 ipm)
Resolution with direct measuring system	0.00001 mm (0.4 mill")

LONGITUDINAL SLIDE: Z AXIS

Max. travel	800 / 1 150 mm (31.5" / 45.25")
Speed	0.01-20 000 mm/min
Resolution with direct measuring system	0.00001 mm
Machine table swiveling range (option)	Up to 8.5°

GUARANTEED WORKING PRECISION

Straightness	
Gauge length 630 mm (24.8")	0.0025 mm (0.000,1")
Gauge length 950 mm (37.4")	0.0030 mm (0.000,12")

CONNECTED LOADS

Total connected load	22 kVA
Air pressure	5.5-7 bar (80-101 psi)

CONTROL SYSTEM

Fanuc Oi-TF PLUS

WHEELHEAD

Swivel range	Type: fixed 0° / 15° / 30°	Type: universal -30° to 190°
Swivel axis		Manual Hirth 2.5°/ automatic Hirth 1°
Fitting taper	dia. 73 mm	dia. 73 mm
Drive power	max. 11.5 kW (15.4 hp)	max. 11.5 kW (15.4 hp)/ max. 12.5 kW (16.7 hp)
Grinding wheel, Ø x width x bore	500 x 63 (80F5) x 203 mm (20" x 2.5" (3.15" F5) x 8")	500 x 80 (110F5) x 203 mm (20" x 3.15" (4.3" F5) x 8")
Circumferential speed	up to 50 m/s (9842 sfpm)	up to 50 m/s (9842 sfpm)

Internal grinding attachment for belt-driven spindles

Mounting bore	dia. 100 mm
Speeds	20 000/40 000 rpm

Internal grinding attachment for motor spindles

Mounting bore	dia. 120 mm (4.73")
Speeds	42 000/60 000/90 000 rpm

UNIVERSAL WORKHEAD

Speed range	1-1500 rpm	1650 rpm
Fitting taper	MT5	ISO50/dia. 110 mm
Bar capacity	dia. 30 mm (1.18")	dia. 50 mm (1.97")
Drive power	2.5 kW (3.35 hp)	3.8 kW (5.1 hp)
Load during live spindle grinding	70 Nm (52 ft-lb)	250 Nm (184 ft-lb)
Roundness accuracy during live spindle grinding	0.0004 mm (0.000,016") (Option: 0.0002 mm / 0.000,008")	0.0004 mm (0.000,016") (Option: 0.0002 mm / 0.000,008")
C axis standard, indirect measuring system	0,0001°	0,0001°

CHUCK WORKHEAD

Speed range	1-1000 rpm
Fitting taper	MT4/Ø 70 mm
Bar capacity	dia. 26 mm (1.02")
Drive power	2.5 kW (3.35 hp)
Load during live grinding	100 Nm (74 ft-lb)
Roundness accuracy during live spindle grinding	0.0004 mm (0.000,016") (Option: 0.0002 mm / 0.000,008")
C axis standard, indirect measuring system, resolution	0.0001°

TAILSTOCK

Fitting taper	MT3/MT4	MT4
Barrel stroke	35 mm (1.37")	60 mm (2.36")
Barrel diameter	50 mm (1.97")	50 mm (1.97")
Fine adjustment for cylindricity corrections	±40 µm (±0.0016")	±40 µm (±0.0016")

FRITZ STUDER AG

The name STUDER stands for more than 113 years of experience in the development and production of precision cylindrical grinding machines. "The Art of Grinding." is our passion, highest precision is our aim and top Swiss quality is our benchmark.

Our product line includes both standard machines, as well as complex system solutions in high-precision cylindrical grinding for machining small and medium-sized workpieces. In addition, we offer software, system integration, and a wide range of services. As well as receiving a complete tailor-made solution, the customer also benefits from over 113 years of know-how in relation to the grinding process.

Our customers include companies from the machine tool industry, automotive, tool and die, the aerospace industry, pneumatics/hydraulics, electronics/electrical engineering, medical technology, the watch industry, and job shops. They value maximum precision, safety, productivity, and longevity. As one of the market and technology leaders in universal, external, internal cylindrical, and out-of-round grinding, with 25,000 systems delivered, STUDER has stood for precision, quality, and durability for decades. STUDER's products and services include hardware, software, and a wide range of services in the pre-sales and after-sales sector.



UNITED MACHINING SOLUTIONS

UNITED MACHINING SOLUTIONS is one of the largest machine tool manufacturers in the world. With around 5,000 employees at over 50 global production, service and sales locations, UNITED MACHINING SOLUTIONS is close to its customers and highly efficient. The group is organized into two divisions: UNITED GRINDING and UNITED MACHINING.

UNITED GRINDING includes the brands MÄGERLE, BLOHM, JUNG, STUDER, SCHAUDT, MIKROSA, WALTER, EWAG and IRPD. Its technologies include surface and profile grinding machines, cylindrical grinding machines, machines for tool machining and machine tools for additive manufacturing.

The UNITED MACHINING division includes the brands AGIE CHARMILLES, CHARMILLES, MIKRON MILL, LIECHTI, STEP TEC and SYSTEM 3R. It includes machines for EDM (Electrical Discharge Machining), high-speed milling and laser technology as well as spindle production and automation solutions.

«We want to make our customers even more successful»

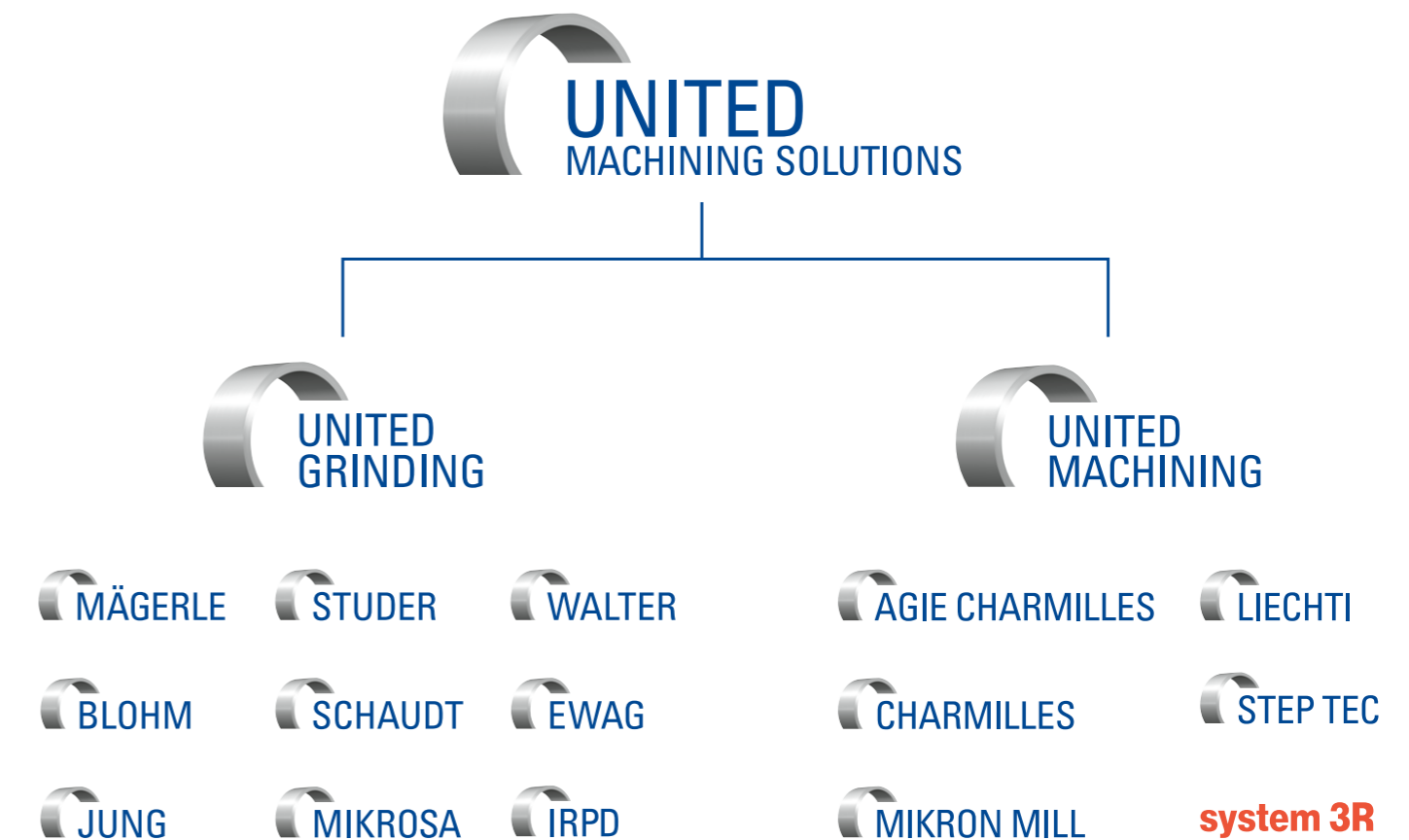



Fritz Studer AG
3607 Thun Switzerland
Switzerland
Phone +41 33 439 11 11
info@studer.com
studer.com



ISO 9001
VDA6.4
certified

