

# S110 / S120

The practical machines  
for your specific grinding solution.



## Key data

The S110/S120 are very flexible internal cylindrical grinding machines for machining medium-sized workpieces.

The S110 has a centre height of 102 mm and a grinding length of max. 120 mm.

The S120 has a centre height of 150 mm (220 mm) and a grinding length of max. 150 mm.

GLOBAL  
TECHNOLOGY LEADER  
PERFECTION  
CUSTOMER FOCUS  
EFFICIENCY  
SAFETY  
SOPHISTICATED PROCESSES  
PRECISION

# The Art of Grinding.

TECHNOLOGY LEADER  
EFFICIENCY  
PERFECTION  
CUSTOMER FOCUS  
PRECISION  
GLOBAL  
SOPHISTICATED PROCESSES  
SAFETY

## Fritz Studer AG

---

The name STUDER stands for more than 100 years of experience in the development and production of precision cylindrical grinding machines. «The Art of Grinding.» is our passion, highest precision is our aim and top Swiss quality is our benchmark.

Our product line includes both standard machines, as well as complex system solutions in high-precision cylindrical grinding for machining small and medium-sized workpieces. In addition we offer software, system integration and a wide range of services. As well as receiving a complete tailor-made solution the customer also benefits from our 100 years of know-how in relation to the grinding process.

Our customers include companies from the machine tool industry, automotive engineering, tool and die makers, the aerospace industry, pneumatics/hydraulics, electronics/electrical engineering, medical technology, the watch industry and job order production. They value maximum precision, safety, productivity and longevity. 24 000 manufactured and delivered systems make us the market leader and are clear evidence of our technological leadership in universal, external, internal and noncircular grinding. Around 800 employees, including 75 apprentices, make it their goal every day to ensure that «The Art of Grinding.» will continue to be closely linked to the name STUDER in the future.

# S110

# S120

If you are looking for a compact machine for internal grinding, the S110 / S120 are a very good choice. Thanks to their small installation space they will fit into any workshop. The S110 / S120 can be configured very flexibly to your requirements and so increase your productivity. Up to three linearly arranged grinding spindles enable external and internal grinding in a single clamping.



# Characteristics

## Dimensions

### S110

- Height of centres 102 mm (4")
- Grinding length max. 120 mm (4.7") (1 spindle)
- Length of parts max. 230 mm (9")

### S120

- Height of centres 150 mm (5.9")
- Grinding length max. 150 mm (5.9") (1 spindle)
- Length of parts max. 650 mm (25.6")

## Hardware

- Up to three HF grinding spindles in a linear arrangement
- HF or belt-driven spindles
- A grinding spindle can be equipped with an external grinding wheel dia. 300 mm (12")
- External and internal grinding are possible in a single clamping
- Full enclosure with sliding door
- Integrated or autonomous loading systems
- Fanuc Oi-TD / Fanuc 31i-A (with loader)





## Software

- StuderWIN or StuderSIM simulation software for the creation and simulation of grinding programs on the machine control or on a PC

## Your advantages

- Small space requirement
- Optimal accessibility
- Low unit costs
- High flexibility
- Simple operation
- Low maintenance costs



### Unique worldwide

The other very compact machine concept. The workpiece is moved on the cross-slide, while the grinding spindles are mounted in a fixed position on the base of the machine. This guarantees stability, offers good accessibility for set-up or workpiece change, and is easily automatable.

The spindle set-up, with up to 3 HF grinding spindles in a linear arrangement, can be optimally designed to meet customer requirements.

The ideal machine for chuck applications for individual components up to small-batch production. A cost-effective solution for high-precision automated grinding can be achieved with the optional, fully integrated automatic loading and unloading system.

- Compact and user-friendly
- Up to three HF grinding spindles in a linear arrangement
- Large selection of internal and external spindles (external wheel up to dia 300 mm (12"))
- C axis for the workhead enabling form and thread grinding
- Manual A axis for precise thread grinding
- Various dressing options
- Full enclosure with sliding door
- Integrated or autonomous loading systems
- Measuring probe
- StuderSIM offline simulation software
- Dovetailed work table for simple positioning of the grinding spindles (optional)
- CNC-controlled Y-axis (vertical)
- Wide range of clamping devices and accessories
- Standardized interface for loader and peripheral devices

# Machine bed

1



The machine bed, comprising of gray cast iron, is cast from a single piece and forms the base for mounting the high-precision cross slide table and the grinding spindle mounting block. The support of the guides for the X axis is cast directly into the machine base. The remaining area on the upper part of the machine base conveys the coolant around the base back into the coolant unit or the coolant cleaning unit, via a coolant tank.

- High geometrical traverse precision
- Effective covering of the guideways

# X and Z axis

2



The generously dimensioned cross slide is manufactured from quality cast iron. Ground and pretensioned high-precision linear bearings (rollers) are used for the longitudinal and cross slides. The feed is provided via ground recirculating ball screws with pretensioned, backlash-free double nut. The guides and recirculating ball screws have an integrated central lubricating system. The X axis is effectively covered by bellows. The Z axis is covered by integrated bellows on both sides. The linear glass scales are protected against contamination by purge air and in addition also by guards. The drive motor (AC servo motor) with direct drive is also completely covered by a guard plate.

# Grinding spindle support/Grinding spindle arrangement

1

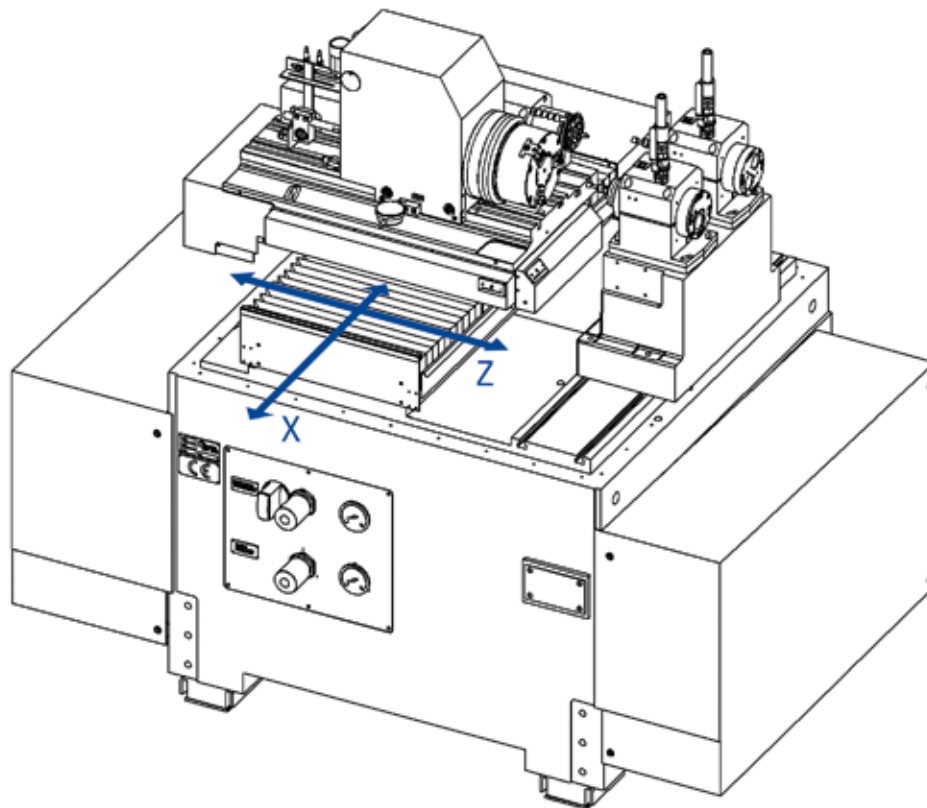

2



3



4



The modular grinding spindle support concept enables optimal adaptation to the respective grinding task. The grinding spindle supports comprise of permanently bolted on solid mounting blocks, either in a single or twin version, depending on the requirements. One, two or three spindles in a linear arrangement can be used in the basic configuration. The use of up to three spindles is possible depending on the specific geometrical situation. In the case of two or three grinding spindles the maximum

possible grinding length is restricted. This diversity of spindle arrangements enables optimal adaptation to your process requirement. For speeds in the upper rpm range up to 120 000 rpm, HF Spindles with an integrated internal cooling circuit can be used. Maximum spindle diameter is 120 mm (4.7"). Smaller diameters up to 45 mm can be used either with the appropriate spindle holder or a reduction sleeve.

1 X and Z axis arrangement

2 1 spindle

3 2 Spindles in linear arrangement

4 3 Spindles in linear arrangement





- Large selection of grinding spindles
- External and internal grinding in a single clamping

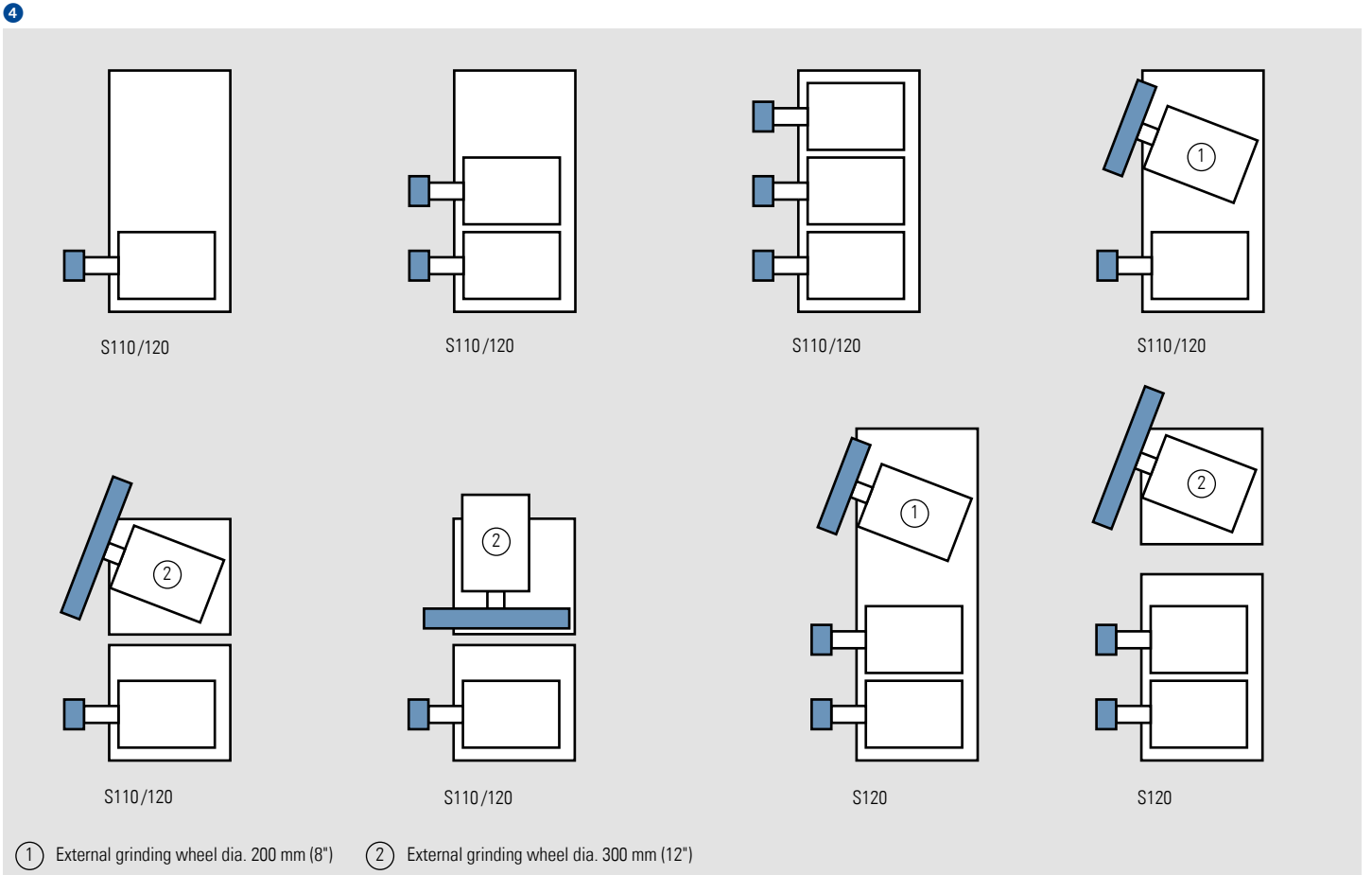



## Workhead



The high-precision workhead is equipped with special bearings and guarantees the highest roundness accuracy. The spindle nose complies to the DIN/ISO 702-1 standard.

A high-precision C axis, with direct measuring system on the workhead spindle, is available for form and thread grinding.

- High roundness accuracy
- Low-maintenance
- Air lift

## Fixed or swivelling Work table



Cones and tapers can be machined in two ways. Either by using a swivelling work table with a manually adjustable range of up to 21 deg (31 deg for S110) or with a fixed table and an appropriately dressed conical grinding wheel.

# Sensor technology/ Measuring probe

1



2



3

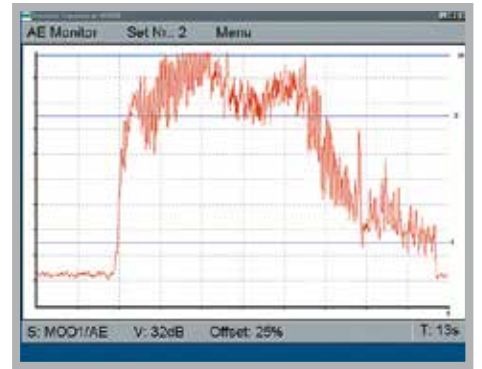

- Air-gap elimination
- Set-up assistance
- Process reliability
- Process optimization

STUDER attaches great importance to optimized grinding processes. Sensor technology plays a significant role here, especially in internal grinding. Three main goals are pursued:

- Air-gap elimination for cycle time reduction
- Process monitoring during grinding and dressing
- Simple registration of grinding wheel and workpiece

With small bore diameters it is particularly difficult to obtain a contact signal. STUDER achieves the best result with a ring sensor consisting of a revolving transmitter ring and a fixed receiver ring. The signal transmission between the two rings is contact-free.

The measuring probe is used for the following operations:

- Length positioning
- Measurement of uninterrupted internal and external diameters for tool compensation when using non-dressable grinding wheels
- Process monitoring on machines with loader

# Dressing

1



2



3

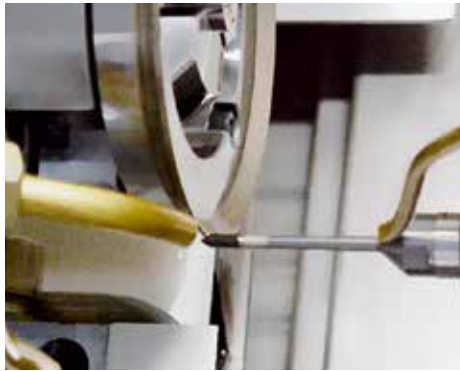

4



The wide variety of dressing options enables optimal adaptation of the machine to the most diverse applications and workpiece requirements. In addition to fixed dressing units, devices for rotating dressing tools can also be mounted. The latter are especially suitable for dressing ceramic-bonded

CBN grinding wheels. In combination with the acoustic touch sensor technology, a precisely defined, minimal amount can be dressed using the Touch-Dressing method. The grinding wheel loss through dressing is thus minimized.

## Dressing unit

The dressing unit is mounted on a hydraulically actuated precision slide with 100 mm (4") stroke.



# Machine control and operation

1



- PCU manual control unit
- EMC-tested control cabinet
- Ergonomically arranged controls

The Fanuc 0i-TD CNC control with active flat color touch screen (15") can be used for a wide variety of grinding tasks. For particularly demanding applications, such as high-precision form or thread grinding, for example, or in the case of machines with integrated STUDER loader, the Fanuc 31i-A is available. Both control units are extremely reliable and optimally tuned to the drive elements. The layout of the elements complies with the relevant safety standards and is EMC-tested. All controls are clearly and

ergonomically arranged. An important role is played by the manual control unit, which facilitates setup close to the grinding process. A special function – the Sensitron electronic contact detection device – reduces downtimes to a minimum.

2

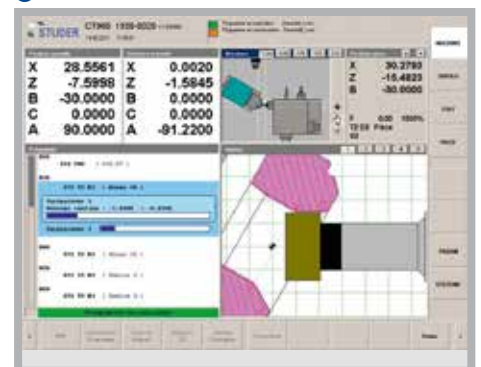

3

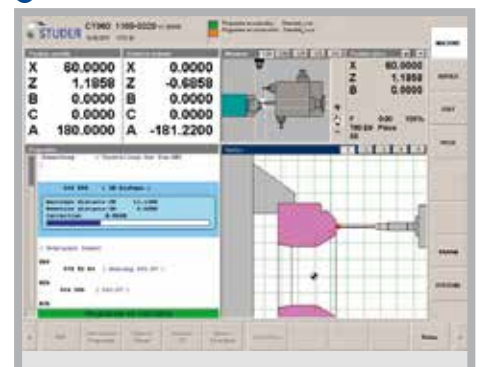

- 1 Fanuc 0i-TD
- 2 Main screen with simulation
- 3 Use of the measuring probe

# The StuderSIM/StuderWIN operating system

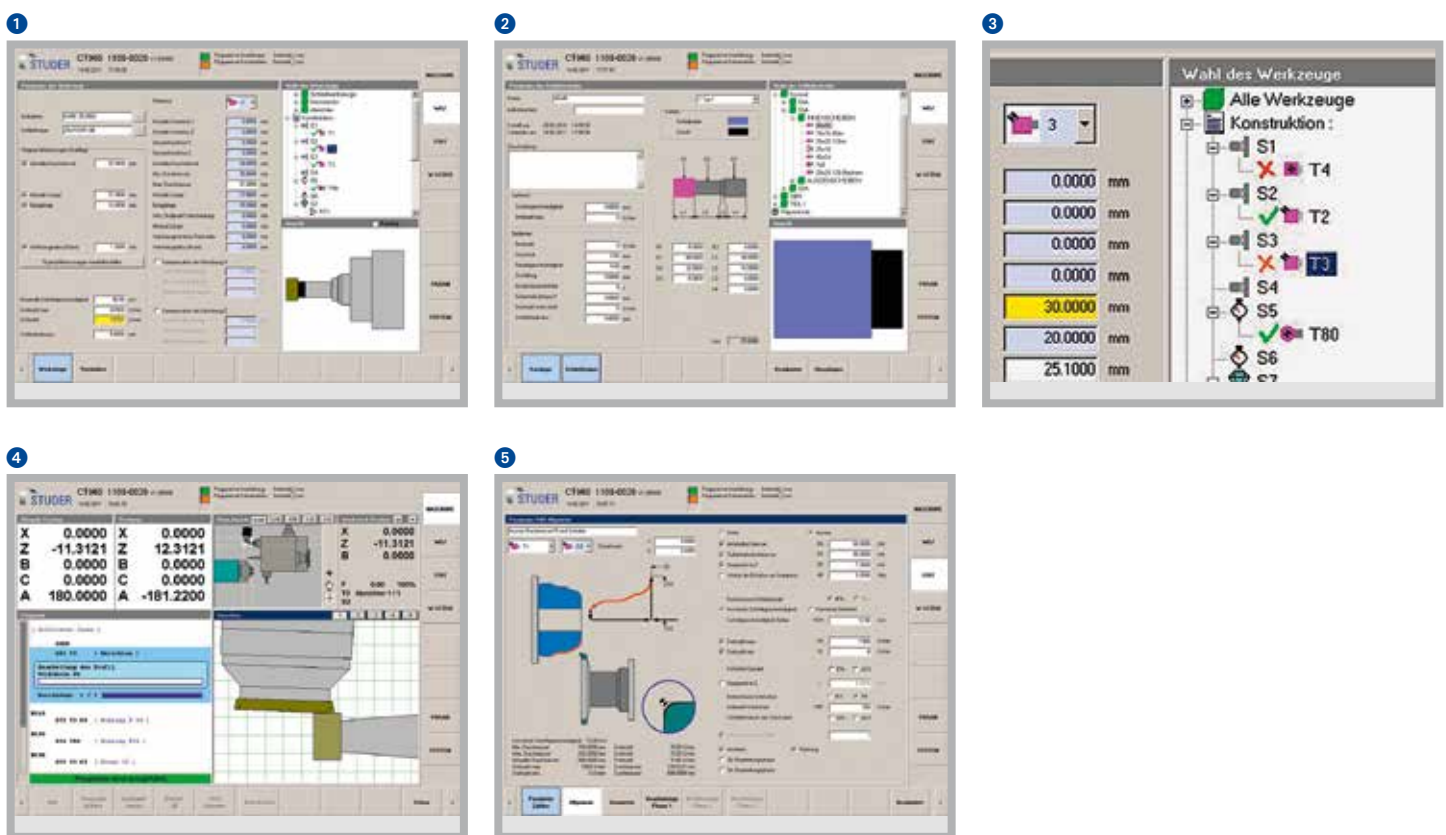

Two different operating systems are available, StuderSIM and StuderWIN. Both operating systems are suitable for a wide variety of internal grinding applications and enable reliable programming of all basic cycles for grinding, dressing and process-supporting measurement. The basic cycles such as face grinding, bore grinding, taper grinding, thread grinding, dressing and gauging are defined in the Parameter Input window. This type of programming

provides great flexibility, while remaining very user-friendly and workshop-oriented. Each cycle is equipped with a dynamic help system, which guides the operator through the grinding data creation process. After programming, the process can be simulated (StuderSIM) and optimized. This ensures reliability, as well as guaranteeing short programming times and increased cost effectiveness.

- 1 Tool management
- 2 Grinding tool catalog
- 3 Tool set-up status

- 4 Dressing simulation
- 5 Grinding data input window

# Automation

1



2



- Automatic production processes
- Integrated quality control
- Standardized loader interfaces

Loading systems are available for the STUDER S110/S120, which can be precisely adapted to the machine application and the machining processes thanks to their modular design. Appropriate peripheral units guarantee seamless integration into the respective production process. The handling systems communicate with the machine via the standardized loader interface

3



and enable even complex handling tasks to be solved. Comprehensive quality control is possible during the grinding process. This means: gauging, post-process gauging, recording, evaluation and correction.

### Integrated loading systems

For medium-sized and small series STUDER offers integrated loading systems, to increase efficiency and flexibility. These cost-effective loaders can be reset extremely quickly and have the advantage that they are controlled from the machine control.

4



Two different peripheral systems are available:

- Two conveyor belts, the height and width of the loading belt is adjustable, enabling very quick changeover from one workpiece to the next.
- Pallets 410 x 400 mm (16.1" x 15.7"), autonomy without operator intervention is two pallets. One pallet can be changed without having to interrupt the machining process.

The maximum workpiece size for both systems is: diameter 60 mm (2.4"), length 80 mm (3.1"). Maximum workpiece weight 1 kg (2.2 lbs).



# Customer Care

STUDER cylindrical grinding machines should fulfil the customer's requirements for as long as possible, work cost-effectively, function reliably and be available at all times. From «start up» through to «retrofit» – our Customer Care is there for you throughout the working life of your machine. 30 professional helplines and more than 60 service technicians are available in your area, wherever you are in the world.

- We will provide you with fast, uncomplicated support.
- We will help to increase your productivity.
- We work professionally, reliably and transparently.
- We will provide a professional solution to your problems.



## Start up

Commissioning  
Warranty extension



## Qualification

Training  
Production support



## Prevention

Maintenance  
Inspection



## Service

Customer service  
Customer consultation  
HelpLine  
Remote service

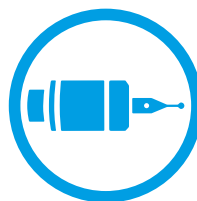

## Material

Spare parts  
Replacement parts  
Accessories



## Rebuild

Machine overhaul  
Assembly overhaul



## Retrofit

Modifications  
Retrofits

# Technical specifications

## Main dimensions

	S110	S120
Height of centres above table	102 mm (4")	150 mm [220 mm] (5.9" [8.7"])
Swing diameter in front of table	dia. 300x40 mm (11.8"x1.6")	dia. 300x40 mm (11.8"x1.6")
Workpiece dia. approx.	120 mm (4.7")	250 mm [350 mm] (9.8" [13.8"])
Length of parts	max. 230 mm (9")	max. 650 mm (25.6")
Grinding length (with 1 spindle)	120 mm (4.7")	150 mm (5.9")

## Transverse axis X

Max. travel	450 mm (17.7")	520 mm (20.5")
Max. speed	12 000 mm/min (472 ipm)	12 000 mm/min (472 ipm)
Resolution	0.0001 mm (0.000,004")	0.0001 mm (0.000,004")

## Longitudinal axis Z

Max. travel	200 mm (7.4")	250 mm (9.8")
Max. speed	12 000 mm/min (472 ipm)	12 000 mm/min (472 ipm)
Resolution	0.0001 mm (0.000,004")	0.0001 mm (0.000,004")

## Grinding spindle support

Spindle set-up	linear	linear
Max. number of spindles	3	3
HF spindle	dia. 45/60/80/100/120 mm (1.7"/2.4"/3.1"/3.9"/4.7")	dia. 80/100/120 mm (3.1"/3.9"/4.7")
Belt-driven spindle	dia. 80 mm (3.1")	dia. 80 mm (3.1")
External grinding wheel	max. 300 mm (12")	max. 300 mm (12")

## Workhead

Rpm range	1 – 1 500 rpm	1 – 1 200 rpm
Fitting taper DIN/ISO 702-1	A2.4/MT5	A2.4/MT5
Bar capacity	dia. 28.6 mm (1.1")	dia. 35.5 mm (1.4")
Driving power	1.4 kW (1.9 hp)	1.6 kW (2.2 hp)
Load on spindle nose	150 Nm (111 ft lbs)	300 Nm (223 ft lbs)
B-axis setting angle (manual)	± 2 deg (opt. + 21/ 31deg)	± 1 deg
C-axis	0.0001 deg	0.0001 deg

## Control unit

Fanuc Oi-TD/Fanuc 31i-A (with loader)

## Connected loads

Total connected load	34 kVA	34 kVA
Air pressure	5 – 10 bar (72 – 145 psi)	5 – 10 bar (72 – 145 psi)
Total weight	2 600 kg (5720 lbs)	3 200 kg (7040 lbs)

**S110**

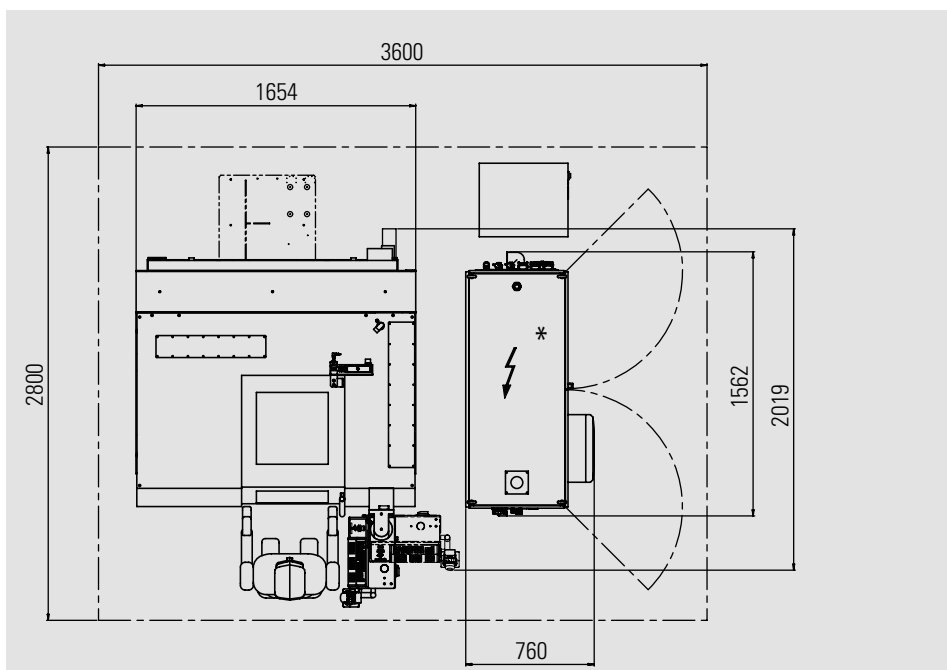

**S120**

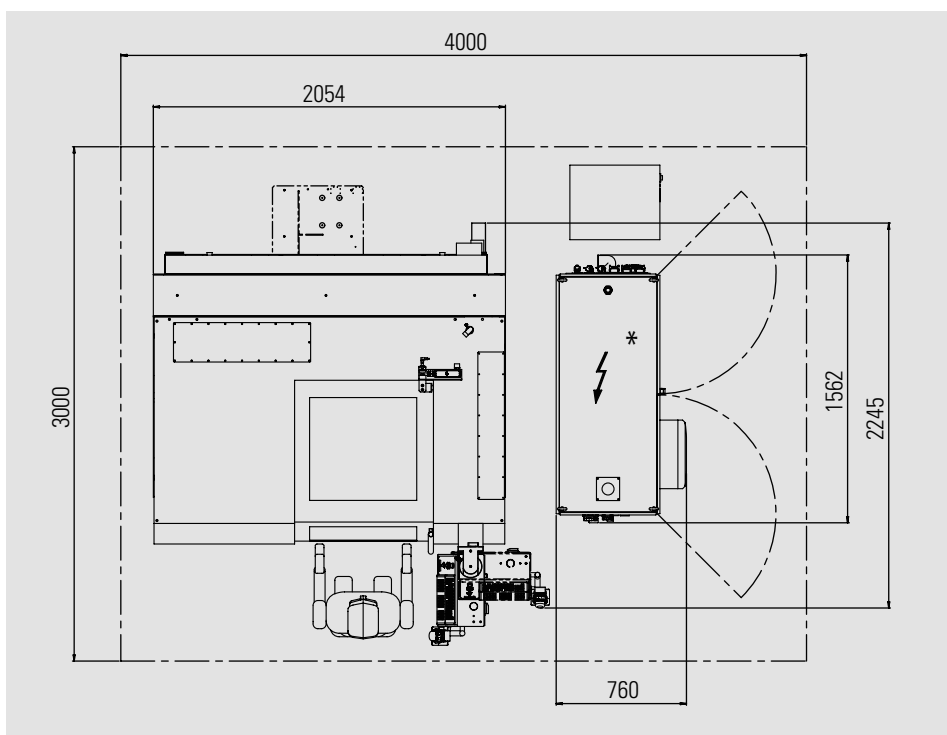

\*The position of the electric cabinet can be defined when ordering.

The information given is based on the technical levels of our machine at the time of this brochure going to print. We reserve the right to further develop our machines technically and make design modifications. This means that the dimensions, weights, colours, etc. of the machines supplied can differ. The diverse

application possibilities of our machines depend on the technical equipment specifically requested by our customers. The equipment specifically agreed with the customer is therefore exclusively definitive for the equipping of the machines, and not any general data, information or illustrations.









Fritz Studer AG  
3602 Thun  
Switzerland  
Phone +41 33 439 11 11  
Fax +41 33 439 11 12  
info@studer.com  
www.studer.com



**ISO 9001**  
**VDA6.4**  
certified





# S122

The highly productive machine  
for small bores.

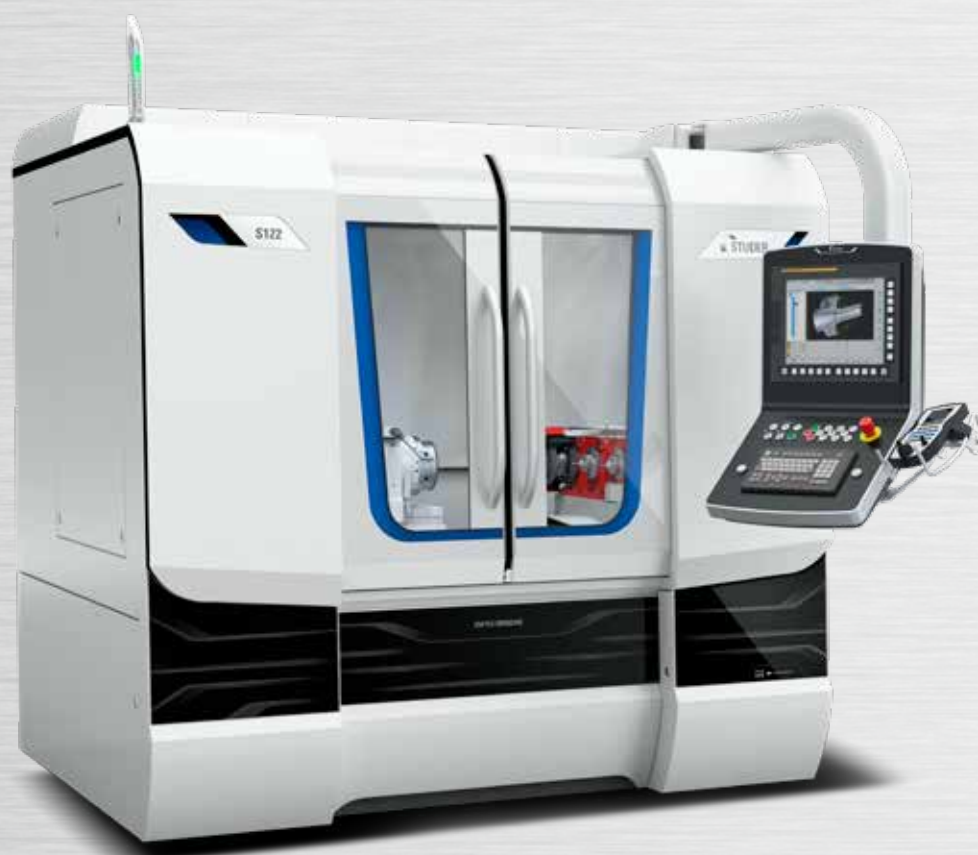

## Key data

The S122 is a CNC production internal cylindrical grinding machine for small to medium-sized workpieces in small and large-scale production. It has a swing diameter of 220 mm. Up to three grinding spindles can be used in a parallel arrangement.

# Highest productivity in internal cylindrical grinding

State-of-the-art technology, compactly packaged in a production internal cylindrical grinding machine in a class of its own – that's the new STUDER S122. Workpieces up to 120 mm (4.7") in length can be machined. The grinding length is a maximum of 110 mm (4.3"). Up to 3 grinding spindles can be used in a pa-

rallel arrangement. One of these can take an external grinding wheel. The basis for the machine's legendary precision is the Granitan® machine bed and the StuderGuide® guide system for the X- and Z-axis.

1



## Granitan® S103 / StuderGuide®

The excellent cushioning behavior of the machine bed ensures outstanding surface quality of the ground workpieces. Temporary temperature fluctuations are extensively compensated by the favorable thermal behavior of Granitan®. The StuderGuide® guide system for the X- and Z-axis is coated with Granitan® S200 wear-resistant guideway surfacing material and offers the highest possible accuracy through the entire speed range with high load capacity and cushioning levels. StuderGuide® extends the benefits of hydrostatic systems and guideways with a patented surface structure. A big advantage of StuderGuide® in comparison with hydrostatic guides is the cushioning component in the direction of motion. The slides are driven by linear motors with direct measuring systems.

- Highest geometrical traversing and guidance accuracy

2

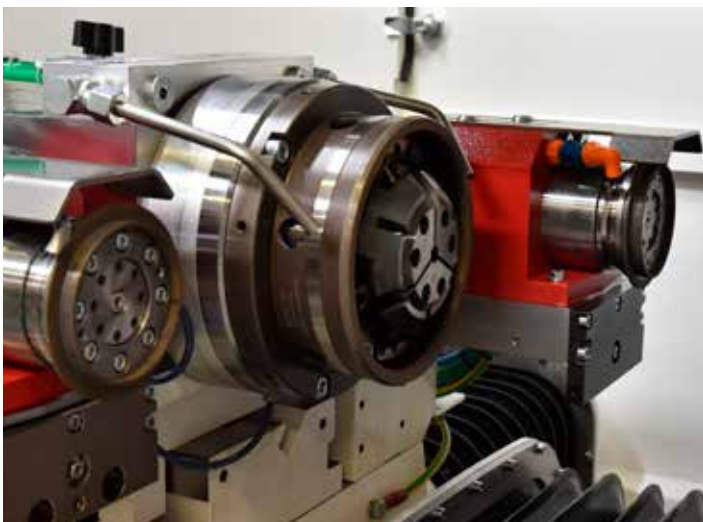

## Workpiece table

The motorized workhead with automatic cylinder correction can be moved in a longitudinal direction. One dressing unit can be mounted in front of and one behind the workhead. The hydraulic retraction unit can accommodate rotating or stationary dressing tools. Speed range up to 4000 rpm, specifically for workpieces with small diameters.

- Movable workhead
- Automatic cylindricity correction

### Control system and operation

The S122 is equipped with a 31-B series Fanuc control unit with integrated PC. The 15" touch screen facilitates intuitive operation and programming of the machine. All controls are clearly and ergonomically arranged.

**The StuderWIN operator interface creates a stable programming environment** and contributes to efficient use of the machine. The possibility of fully integrating the in-process gauging and sensor technology for process monitoring as well as contact detection and balancing systems in the operator interface enables standardized programming of the different systems.

- Ergonomically arranged operating elements
- Latest software technology



### Grinding spindles

The modular spindle support concept enables optimal adaptation to the grinding task.

Up to 3 spindles in a parallel arrangement can be used on the S122. One spindle can be equipped with an external grinding wheel. The spindles can be individually equipped with the proven arbor deflection compensation system. This enables high-precision machining even with the smallest arbor diameters.

- Modular system
- Arbor deflection compensation



### Automation

Different loading systems are available for the S122, which can be precisely adapted to the machine application and the machining processes thanks to their modular design. The integrated loader is distinguished by its advantageous price and the ease of setup and resetting. However, complex systems with pre- and post-process stations, automatic correction, recording and evaluation can also be easily implemented on the S122.

- Automatic production processes
- Standardized loader interfaces





# Technical data

## Main dimensions

Swing diameter above table	220 mm (8.6")
Workpiece dimension	max. dia. 70 x 120 mm (2.8"x4.7")
Workpiece weight	max. 2,5 kg (5.5 lbs)
Internal grinding length	max. 110 mm (4.3")
External grinding length	max. 40 mm (1.6")

## Transverse axis X

Max. travel	350 mm (13.8")
Speed	0.001 – 20 000 mm/min (0.000,04-787 ipm)
Resolution	0,00001 mm (0.000,000,4")

## Longitudinal axis Z

Max. travel	350 mm (13.8")
Speed	0,001 – 20 000 mm/min (0.000,04-787 ipm)
Resolution	0,00001 mm (0.000,000,4")

## Grinding spindle support

Linear spindles up to max.	3
----------------------------	---

### Internal grinding

Locating bore	dia. 100/120 mm (3.9"/4.7")
Speeds	6 000 – 120 000 rpm

### External grinding

Peripheral speed	50 m/s (9840 sfpm)
Fitting taper	HSK C50 axial
Grinding wheel	dia. 150 x 20 mm (5.9" x 0.8")

## Motor workhead

Rpm range	1 – 4 000 rpm
Holding fixture	A4 according to DIN/ISO 702-1 / MK5
Bar capacity	dia. 35,5 mm (1.4")
Load for live spindle grinding	25 Nm (19 ft lbs)
<b>C-axis for form grinding</b>	
- High-precision, direct measuring system	0,0001 deg

## Control system

Fanuc 31 i -B with integrated PC
15" touch screen

## Connected loads

Total connected load	32 kVA
Air pressure	5,5 bar (80 psi)
Extraction capacity for cooling lubricant mist	1 200 – 1 800 m <sup>3</sup> /h

## Installation dimensions

Machine dimension L x W ( without operating panel )	2 110 x 1 625 mm (83" x 64")
Total weight	4 350 kg (9570 lbs)



Fritz Studer AG  
3602 Thun  
Switzerland  
Tel. +41 33 439 11 11  
Fax +41 33 439 11 12  
info@studer.com  
www.studer.com