

S11

The super-productive machine
for small workpieces.



Key data

The S11 is a production cylindrical grinding machine for small workpieces. It has a distance between centres of 200 mm and a centre height of 125 mm. It can machine workpieces with a maximum weight of 3 kg.

GLOBAL
TECHNOLOGY LEADER
PERFECTION
CUSTOMER FOCUS
EFFICIENCY
SAFETY
SOPHISTICATED PROCESSES
PRECISION

The Art of Grinding.

TECHNOLOGY LEADER
EFFICIENCY
PERFECTION
CUSTOMER FOCUS
PRECISION
GLOBAL
SOPHISTICATED PROCESSES
SAFETY

Fritz Studer AG

The name STUDER stands for more than 100 years of experience in the development and production of precision cylindrical grinding machines. «The Art of Grinding.» is our passion, highest precision is our aim and top Swiss quality is our benchmark.

Our product line includes both standard machines, as well as complex system solutions in high-precision cylindrical grinding for machining small and medium-sized workpieces. In addition we offer software, system integration and a wide range of services. As well as receiving a complete tailor-made solution the customer also benefits from our 100 years of know-how in relation to the grinding process.

Our customers include companies from the machine tool industry, automotive engineering, tool and die makers, the aerospace industry, pneumatics/hydraulics, electronics/electrical engineering, medical technology, the watch industry and job order production. They value maximum precision, safety, productivity and longevity. 24 000 manufactured and delivered systems make us the market leader and are clear evidence of our technological leadership in universal, external, internal and noncircular grinding. Around 800 employees, including 75 apprentices, make it their goal every day to ensure that «The Art of Grinding.» will continue to be closely linked to the name STUDER in the future.

S11

If space-saving is your priority, then the S11 is the right machine for you. In a space of less than 1.8 m² the S11 produces extremely efficiently and reliably with a grinding wheel dia. 500 mm. The S11 can be set up quickly and easily thanks to the lean StuderWIN*focus* software, geared to the most important features. It can also be easily automated with an integrated loading/unloading device.

Characteristics

Dimensions

- Distance between centres 200 mm
- Height of centres 125 mm
- Grinding wheel diameter 500 mm

Hardware

- Grinding wheel arrangement 0 or 20 deg
- Grinding wheel right dia. 500 x 63 x 203 mm
- Two full enclosure variants
 - With large door opening, ideal for manual loading or small loader systems
 - With loading hatch for top loading, especially suitable for the interconnection of several machines
- Dual axis cover (telescopic and bellows)
- Granitan® S103 mineral casting machine base
- PCT touchscreen (Projective Capacitive Touch)



Software

- Easy programming with the new operator interface
- StuderWIN *focus* on the Fanuc 0i-TF
- Simple and clear process visualization
- Software optimized for touchscreen
- In-process gauging software integrated into the machine control
- StuderWIN programming software for producing grinding and dressing programs on a PC
- StuderGRIND programming software for the creation of grinding and dressing programs directly on the machine control, or on an external PC



The S11 is a production machine, which is precisely tailored to the desired process. Highly dynamic axis drives, high-quality STUDER guideway systems, short reaction times and optimized traverses form the basis of the S11. The high-speed grinding option (HSG) contributes to increasing productivity with its peripheral speed of up to 140 m/s.

With a floorspace requirement of less than 1.8 m², it is extremely compact and will fit in any workshop.

Precision is the result of perfect interaction between a large number of different factors. The basis is the Granitan[®] S103 machine base with its excellent damping characteristics and favorable thermal behavior. The modules are ideally suited to each other and produced with customary STUDER precision.

Granitan[®] S103 mineral-casting machine base

1



- Vibration-damping
- Thermal stability

The material structure developed by STUDER, which has proved its superb efficiency over many years, is produced in the company's own plant using the most modern industrial techniques.

- The excellent dampening behavior of the machine base ensures outstanding surface quality of the ground workpieces. The service life of the grinding wheel is also increased, leading to reduced downtimes.
- Temporary temperature fluctuations are extensively compensated for by the favorable thermal behavior of Granitan[®], resulting in high dimensional accuracy at all times. This provides high stability throughout the day.

2

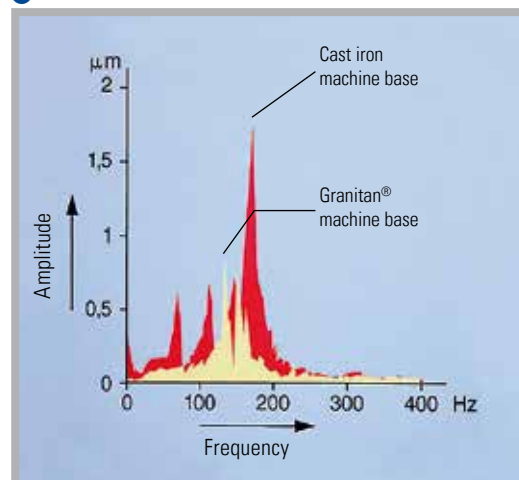

Cross-slides

1**2**

- High geometric traverse precision
- Effective covering of the guideways

The X and Z-axis are designed as a cross slide, and the workpiece table is bolted permanently to the machine. This cross-slide system has been proven for years in STUDER production cylindrical grinding machines. High-precision guideway systems and dynamic axis drives in conjunction with robust design guarantee high process reliability in production.

The cross slide forms a self-contained unit. Both axes have linear guideways mounted on roller bearings.

The axes are effectively protected. Bellows, guideways and measuring system are protected from grinding mist and dust underneath the telescopic sheet. The glass scales of both axes have a resolution of 0.00001 mm.

Wheelhead

①



②

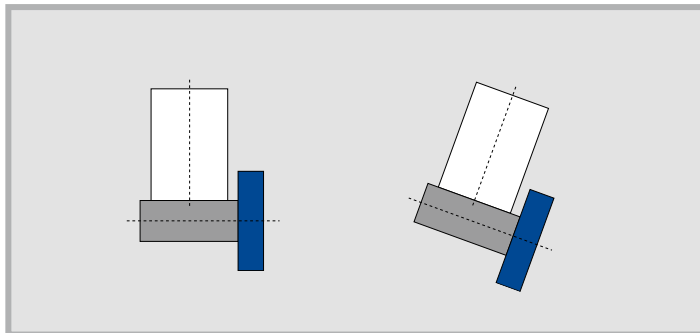

- High performance
- Cutting speed up to 63 m/s (HSG 140 m/s)
- Grinding wheel diameter 500 mm

The wheelhead with grinding wheel on the right is available with a plunge angle of 0 or 20 deg. The motor spindle makes a large contribution to the legendary Studer precision. It is manufactured completely in-house. The motor spindle has a hollow shaft with integrated contact detection and balancing unit.

Workhead

1



- High roundness accuracy
- Low-maintenance

With its high-precision roller bearings the workhead is used for grinding between fixed centres and for live spindle grinding. The powerful workhead spindle has a MT4 fitting taper.

The machine can also be fitted with a specially designed chuck workhead for chuck applications. The workheads are mounted on roller bearings, are low-maintenance and possess an excellent roundness accuracy of below 0.0004 mm (optionally 0.0002 mm) during live spindle grinding operations.

The airlift simplifies adjustment when setting up or resetting the workhead. The fine adjustment enables taper corrections in the μm -range during live spindle grinding.

2



Tailstock

1



2



- Taper corrections
- Thermal stabilization via overflow capacity

The rigid tailstock with generously dimensioned barrel is extremely stable and guarantees optimum grinding conditions for grinding between centres. The barrel slides in effectively covered floating bearings.

The fine adjustment enables taper corrections in the range below 1 μm when grinding between centres.

Dressing



An easy-cutting grinding wheel is essential for cost-effective, high-quality grinding. In order to create a flexible and optimal dressing process that coordinates with the properties of the workpiece, tool and materials, STUDER provides a large selection of dressing units. The grinding wheel profile and dressing parameters are easily defined via macros. Another STUDER speciality is the grinding wheel reference points (T-numbers). This enables programming with normal dimensions, which considerably facilitates the development of grinding programs.

A software package is available to fine tune the dressing process and includes additional dressing functions.

- 1 Dressing fleece
- 2 Dressing spindle
- 3 Entry mask for dressing

Operation and programming

1



2

- Compact manual control unit
- EMC-tested control cabinet
- Ergonomically designed
- Operating elements

The S11 features a Fanuc Oi-TF. The clear and ergonomic arrangement of the control elements guarantees efficient operation.

The projective-capacitive touchscreen, with continuous glass plate over the entire panel, is resistant to scratches and dirt and can even be operated with gloves without problem. An important role is played by the manual control unit, which facilitates setup close to the grinding process.

The control cabinet is installed behind the machine, flush or angled according to customer requirement. The layout of the elements complies with the relevant safety norms and is EMC-tested.



StuderWINfocus

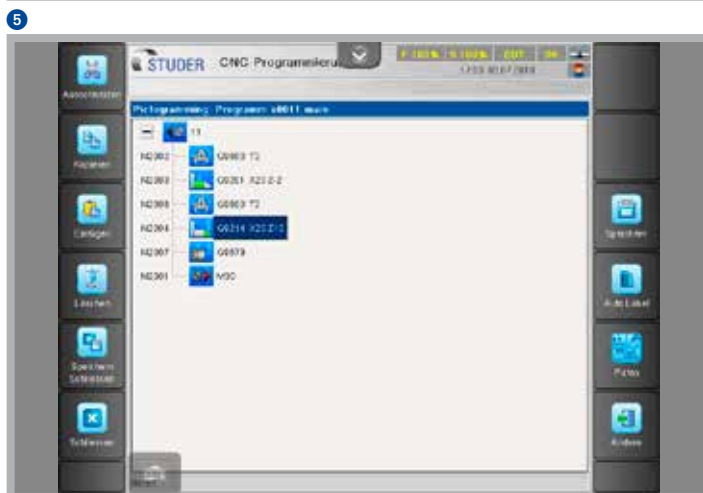
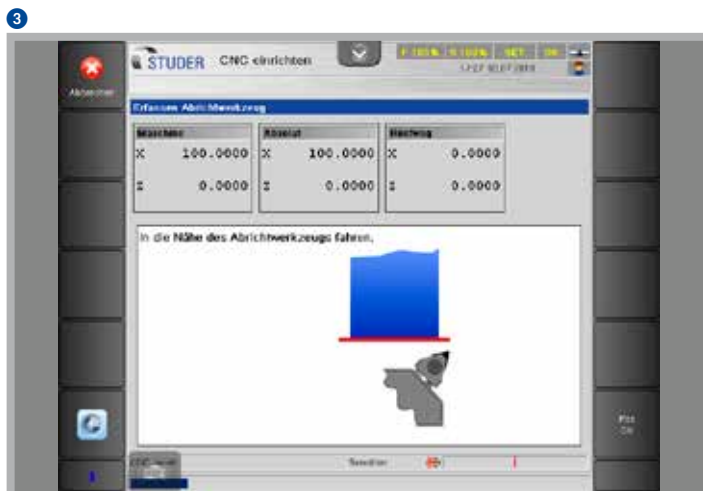

The StuderWINfocus operator interface, based on the tried and tested StuderWIN, creates a stable programming environment and contributes to efficient use of the machine. The possibility of fully integrating the in-process gauging and sensor technology for process control as well as contact detection and automatic balancing systems in the operator interface enables standardized programming of the different systems. The compact and refined concept of the S11 is completed by a grinding software program which was developed by STUDER and is constantly further optimized in

cooperation with users. This software offers:

- StuderPictogramming: The operator strings the individual grinding functions together – the control unit generates the ISO code.
- Microfunctions: Free programming of grinding and dressing process sequences for optimization of the grinding process.
- The integrated basic value computer for technological calculations assists the programmer in grinding technology calculations.
- STUDER standard grinding cycles

- 1 Energy screen as start screen
- 2 Drop-down menu with freely definable function keys
- 3 Registration of the dressing tool during guided set-up process

- 4 Programming of a standard grinding wheel
- 5 Program view with StuderPictogramming
- 6 Cycle view with Studer pictogramming and faded-in, virtual keyboard

Automation

①



②

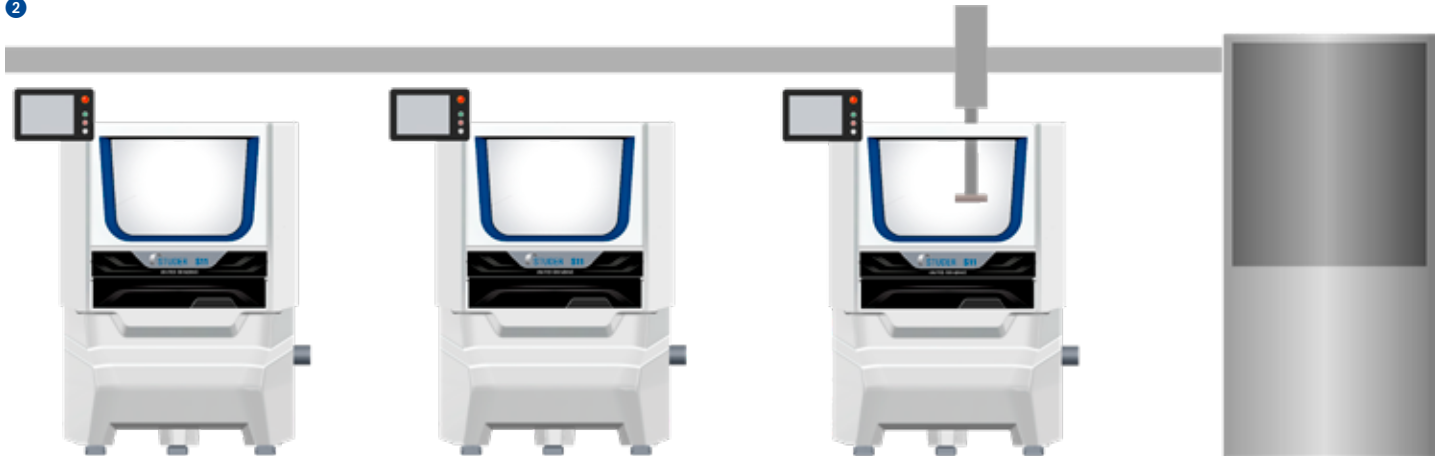

- Automated production processes
- Integrated quality control
- Standardized loading interfaces

The S11 is designed as a production grinding system. It is available in two casing variants. With the rounded casing, it is particularly suitable for manual loading or in combination with small handling systems. A new casing type is optimized for vertical loading with a hatch. It is therefore perfect for an interlinked production system, in which the machines are loaded and unloaded via portal cranes. Both designs stand out with their excellent accessibility and ergonomic features.

The corresponding peripherals ensure seamless integration into the respective production process. The handling systems used communicate with the machine via the standardized loader interface and enable even complex handling tasks to be solved.

Comprehensive quality control is possible during the grinding process. Optimum accessibility is guaranteed at all times by service doors on the left and right. Pneumatic components are integrated into the machine bed so that they are clear and easily accessible.

Customer Care

STUDER cylindrical grinding machines should fulfil the customer's requirements for as long as possible, work cost-effectively, function reliably and be available at all times. From «start up» through to «retrofit» – our Customer Care is there for you throughout the working life of your machine. 30 professional helplines and more than 60 service technicians are available in your area, wherever you are in the world.

- We will provide you with fast, uncomplicated support.
- We will help to increase your productivity.
- We work professionally, reliably and transparently.
- We will provide a professional solution to your problems.



Start up

Commissioning
Warranty extension



Qualification

Training
Production support



Prevention

Maintenance
Inspection



Service

Customer service
Customer consultation
HelpLine
Remote service

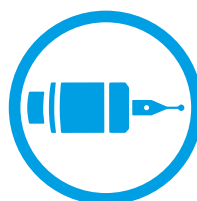

Material

Spare parts
Replacement parts
Accessories

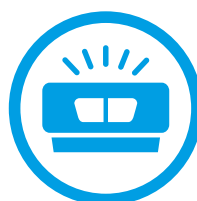

Rebuild

Machine overhaul
Assembly overhaul



Retrofit

Modifications
Retrofits

Technical Data

Main dimensions

Distance between centres	200 mm (7.9")
Grinding length	80 – 150 mm (3.15" – 5.9")
Height of centres	125 mm (4.9")
Max. workpiece weight	3 kg (6.6 lbs)

Cross-slides: X-axis

Max. travel	210 mm (8.3")
Speed	0.001 – 15 000 mm/min (0.000,04-590 ipm)
Resolution	0,00001 mm (0.000,000,4")

Longitudinal slide: Z-axis

Max. travel	210 mm (8.3")
Speed	0.001 – 15 000 mm/min (0.000,04-590 ipm)
Resolution	0,00001 mm (0.000,000,4")

Wheelhead

Plunge angle	0 deg or 20 deg
Driving power	4,5 kW (6,1 hp)
Grinding wheel left/right	dia. 508 / 203x63 mm (20"/8"x 2.5")
Circumferential speed	63 m/s (12 400 sfpm)
Optional high-speed grinding	
Drive power	6,9 kW (9.4 hp)
Grinding wheel	dia. 400 / 127x40 mm (16"/5"x1.6")
Circumferential speed	up to 140 m/s (27 552 sfpm)

Universal workhead MT4

For live spindle grinding or external grinding between centres

Speed range	1 – 2 500 rpm
Driving power	2,2 kW (3 hp)
Roundness during live spindle grinding operations	0,0004 mm (Option: 0,0002 mm) (0.000,016" [0.000,008"])

Chuck workhead MT4

For live spindle grinding or external grinding with revolving centre

Speed range	1-3000 rpm
Driving power	2,2 kW
Roundness during live spindle grinding operations	0,0004 mm (Option: 0,0002 mm) (0.000,016" [0.000,008"])

C-axis for form grinding

– Standard, indirect measuring system	0,0001 deg
– High-precision, direct measuring system	0,0001 deg

Center workhead MT3

For external grinding between centres

Speed range	1 – 2 500 rpm
Driving power	2,2 kW (3 hp)

Tailstock spectrum

Fitting taper	MT3
Barrel stroke	35 mm (1.37")
Fine adjustment	±40 µm (0.0016")

Control unit

Fanuc 0i-TF

Connected loads

Total connected loads	13 kVA
Air pressure	5,5 bar (80 psi)
Total weight	2 300 kg (5 060 lbs)

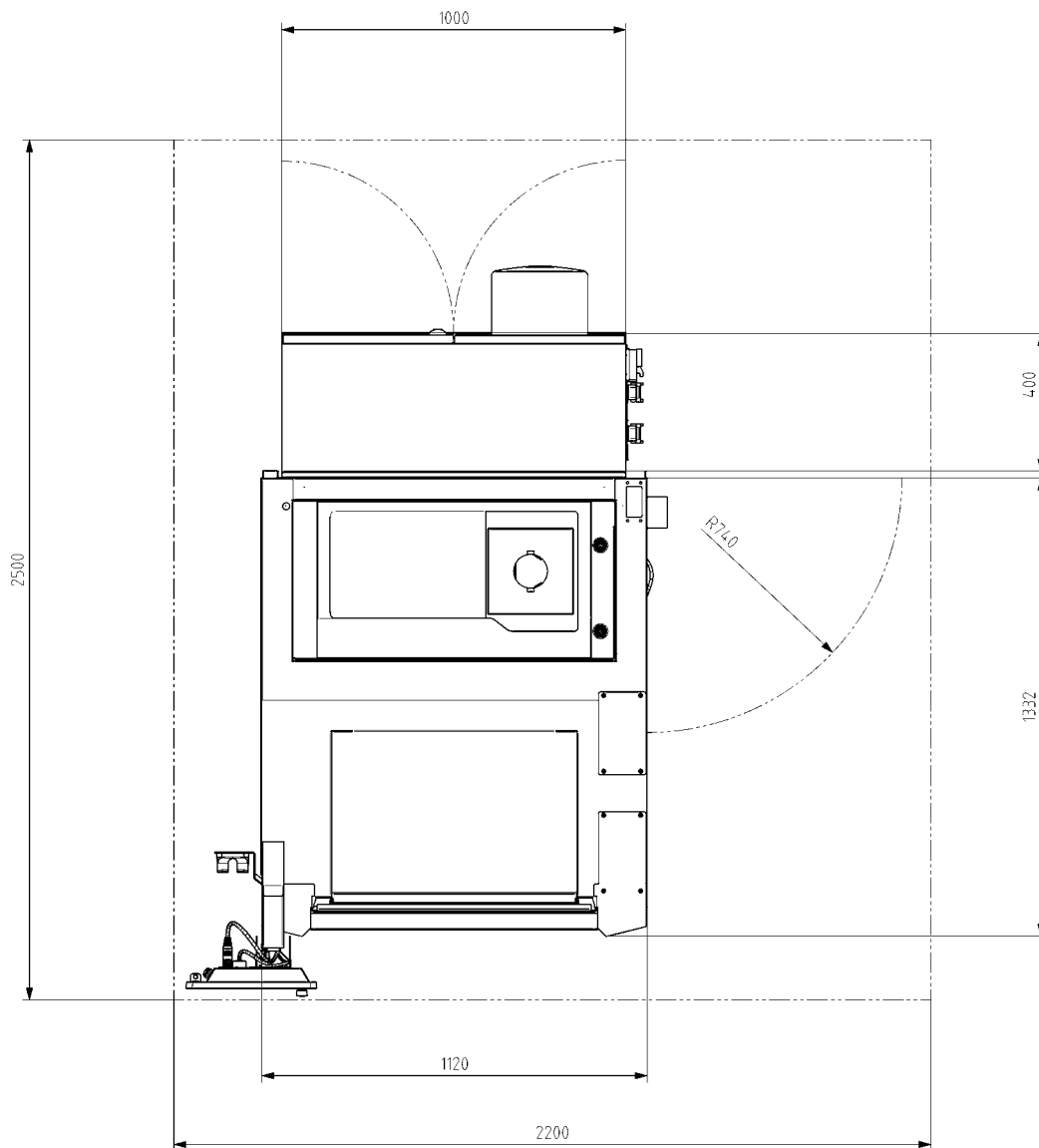

The information given is based on the technical levels of our machine at the time of this brochure going to print. We reserve the right to further develop our machines technically and make design modifications. This means that the dimensions, weights, colors, etc. of the machines supplied can differ. The diverse application possibilities of our machines depend on the technical equipment specifically requested by our customers. The equipment specifically agreed with the customer is therefore exclusively definitive for the equipping of the machines, and not any general data, information or illustrations.



Fritz Studer AG
3602 Thun
Switzerland
Phone +41 33 439 11 11
Fax +41 33 439 11 12
info@studer.com
www.studer.com



ISO 9001
VDA6.4
certified



S22

The production platform
for your individual grinding solution.



Key data

The S22 is a production platform for the mass production of medium-sized workpieces. It has distances between centres of 650/1100 mm and centre heights of 175/225 mm. It can machine workpieces with a maximum weight of 150 kg.

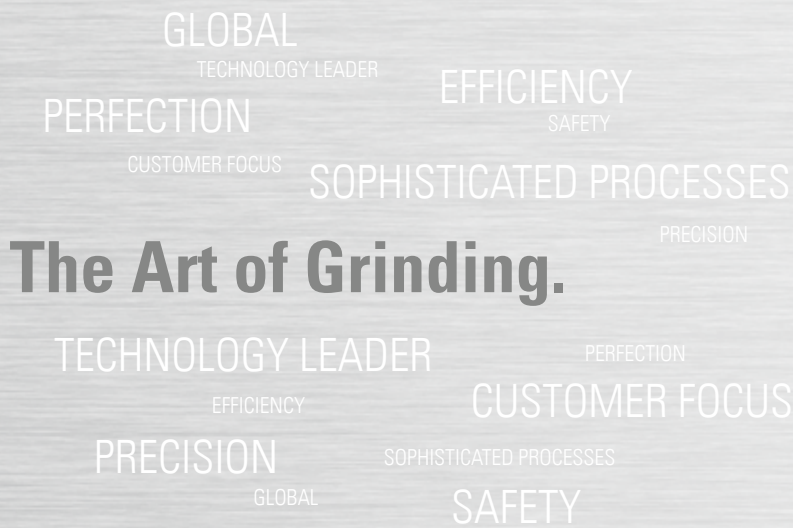

Fritz Studer AG

The name STUDER stands for more than 100 years of experience in the development and production of precision cylindrical grinding machines. «The Art of Grinding.» is our passion, highest precision is our aim and top Swiss quality is our benchmark.

Our product line includes both standard machines, as well as complex system solutions in high-precision cylindrical grinding for machining small and medium-sized workpieces. In addition we offer software, system integration and a wide range of services. As well as receiving a complete tailor-made solution the customer also benefits from our 100 years of know-how in relation to the grinding process.

Our customers include companies from the machine tool industry, automotive engineering, tool and die makers, the aerospace industry, pneumatics/hydraulics, electronics/electrical engineering, medical technology, the watch industry and job order production. They value maximum precision, safety, productivity and longevity. 24 000 manufactured and delivered systems make us the market leader and are clear evidence of our technological leadership in universal, external, internal and noncircular grinding. Around 800 employees, including 75 apprentices, make it their goal every day to ensure that «The Art of Grinding.» will continue to be closely linked to the name STUDER in the future.

S22

If productivity is important to you, we recommend the S22. This is a production platform, which is precisely configured for your grinding tasks. The S22 can be perfectly integrated into your production line. It allows you to machine medium-sized workpieces with different technologies - from conventional cylindrical grinding through form and thread grinding to high speed grinding (HSG) with peripheral speeds up to 140 m/s.

Characteristics

Dimensions

- Grinding length max. 800 mm
- Centre height 175/225 mm
- Diameter of grinding wheel up to 610 mm

Hardware

- Granitan® S103 mineral-casting machine base
- Cross slide X: anti-friction guideways with ball-screw
- Longitudinal slide Z: guideway with patented surface structure and ball-screw linear drive
- C axis for the workhead
- Application-specific workhead concepts
- Additional NC axis for profiling the grinding wheel
- Full enclosure with movable front panels for optimal accessibility
- Integrated loading unit or loading cell for loading and unloading from left, right or above
- Large range of accessories

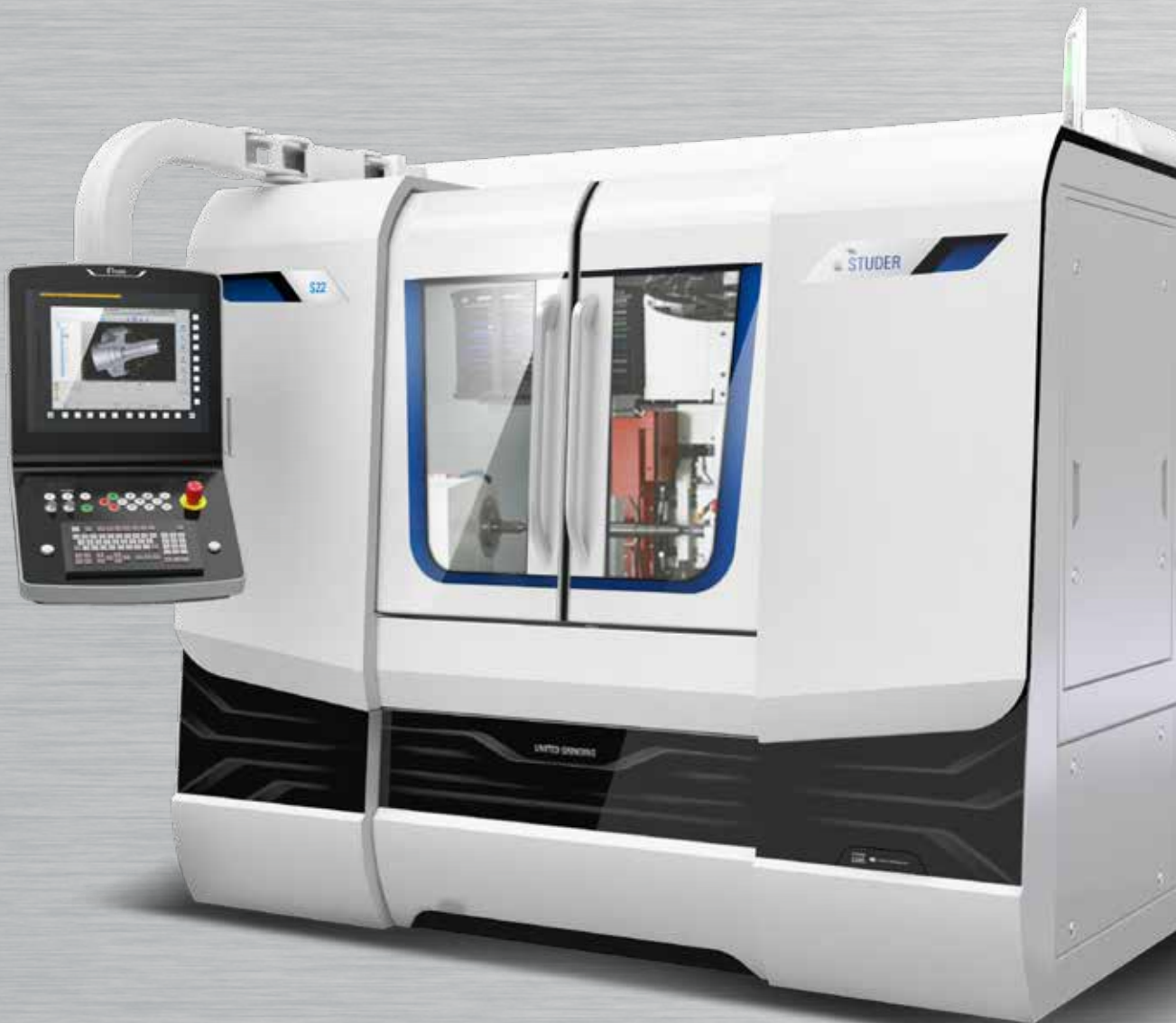

Software

- Easy programming with StuderWIN on Fanuc 31i-A
- StuderGRIND programming software to create grinding and dressing programs
- Standardized interfaces for loading and peripheral devices



The production platform for your individual grinding solution.

The S22 with its extensive expansion options can be configured for every grinding application to be the perfect production machine, without generating needless interfaces.

Highly dynamic axis drives, high-quality STUDER guideway systems, short reaction times and optimized traverses form the basis of the S22. The high-speed grinding option (HSG) contributes to increasing productivity with its peripheral speed of up to 140 m/s. The X- and Z-axis are mounted in the form of cross slides; the workpiece table is firmly bolted to the machine. This cross-slide system has proved itself in STUDER production machines for many years.

Precision

Precision is the result of perfect interaction between a large number of different factors. The base is the Granitan® S103 machine bed with its excellent damping characteristics and favorable thermal behavior. The modules are ideally suited to each other and produced with customary STUDER precision. The large distance between the guideways and the very rigidly constructed slides form the basis for the precision and productivity of this machine. All components involved in defining precision are temperature-stabilized.

Granitan[®] S103 mineral-casting machine base

1



2



- Vibration-damping
- Thermal stability
- Non-wearing

The material structure developed by STUDER, which has proved its superb efficiency over many years, is produced in the company's own plant using the most modern industrial techniques.

- The excellent cushioning behavior of the machine base ensures outstanding surface quality of the ground workpieces. The service life of the grinding wheel is also increased, leading to reduced downtimes.

- Temporary temperature fluctuations are extensively compensated for by the favorable thermal behavior of Granitan[®], resulting in high dimensional accuracy at all times. This provides high stability throughout the day.
- The V and flat guideways for the longitudinal and cross slides are moulded directly into the machine base and are provided with a non-abrasive Granitan[®] S200 slide-way coating.

3

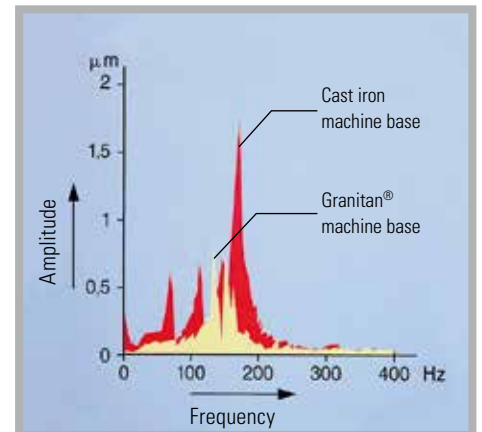

The guideways offer the highest possible accuracy through the entire speed range with high load capacity and cushioning levels. Thanks to the robust and maintenance-free design, these excellent guideway characteristics are more or less completely retained. The non-magnetic machine bed is particularly suitable for linear motors.

1 Machine base with Z guideways

2 Guideways with patented surface structure

3 Vibration behavior of gray cast iron and Granitan[®] S103

Cross-slides

1

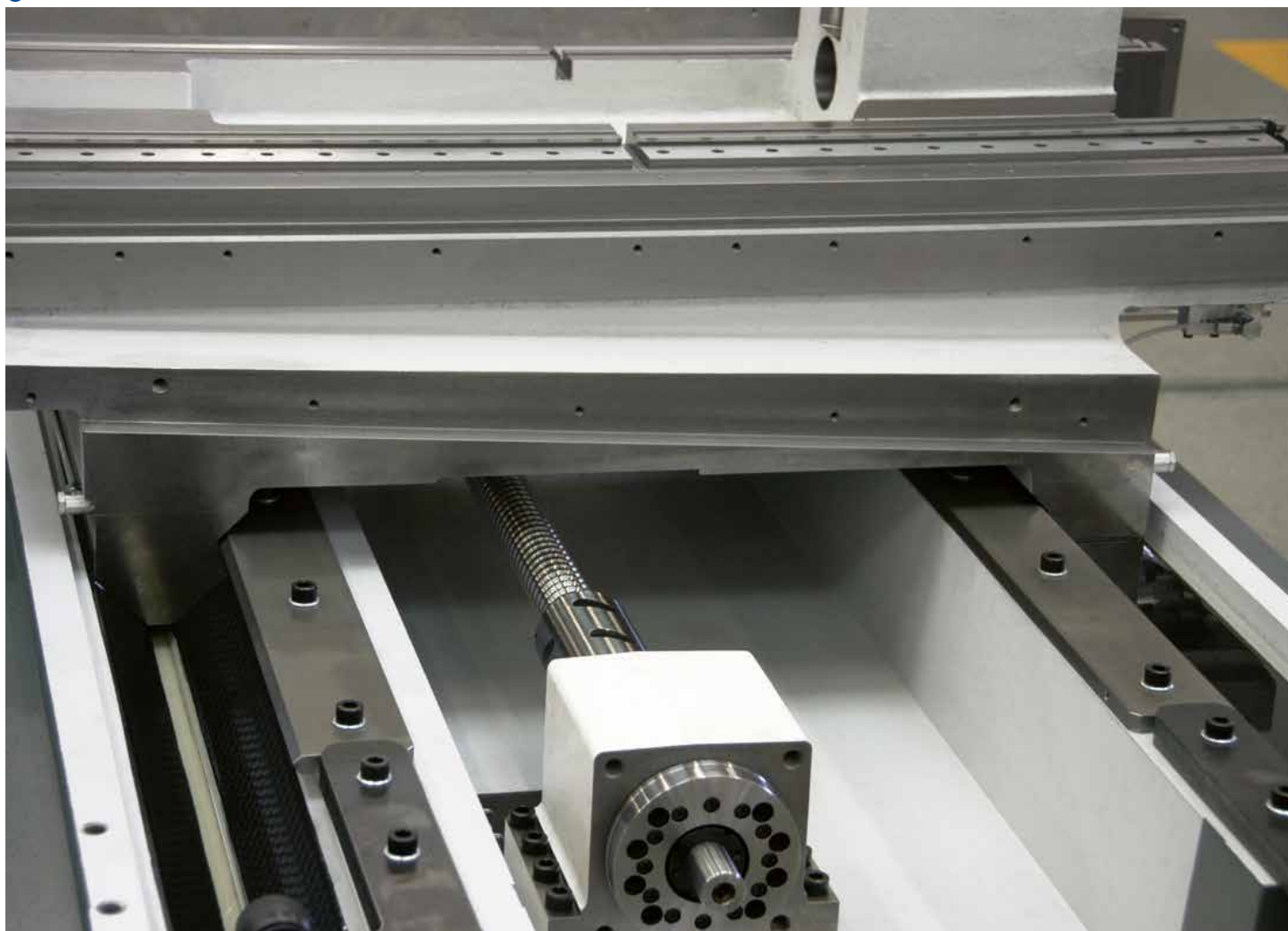

- High geometric traverse precision
- Effective covering of the guideways

The X- and Z-axis are mounted in the form of cross slides; the workpiece table is firmly bolted to the machine. This cross-slide system has proved itself in STUDER production circular grinding machines for years.

The generous guide spacings provide the basis for a stable and robust design of cross slide and wheelhead.

High-precision guideway systems and dynamic axis drives in conjunction with robust design guarantee high process reliability in production.

X-axis

Anti-friction guideways with ball-screw.

Z-axis

Guideway with patented surface structure and ball-screw. The surface structure prevents the slides from swimming up and also eliminates the stick-slip effect, which is otherwise noted in conventional guideways. The linear measuring system is mounted on the slide and is therefore not influenced by variations in temperature. The thermal expansion of the ball-type spindles is compensated for by direct reading on the glass scale.

Wheelhead

1

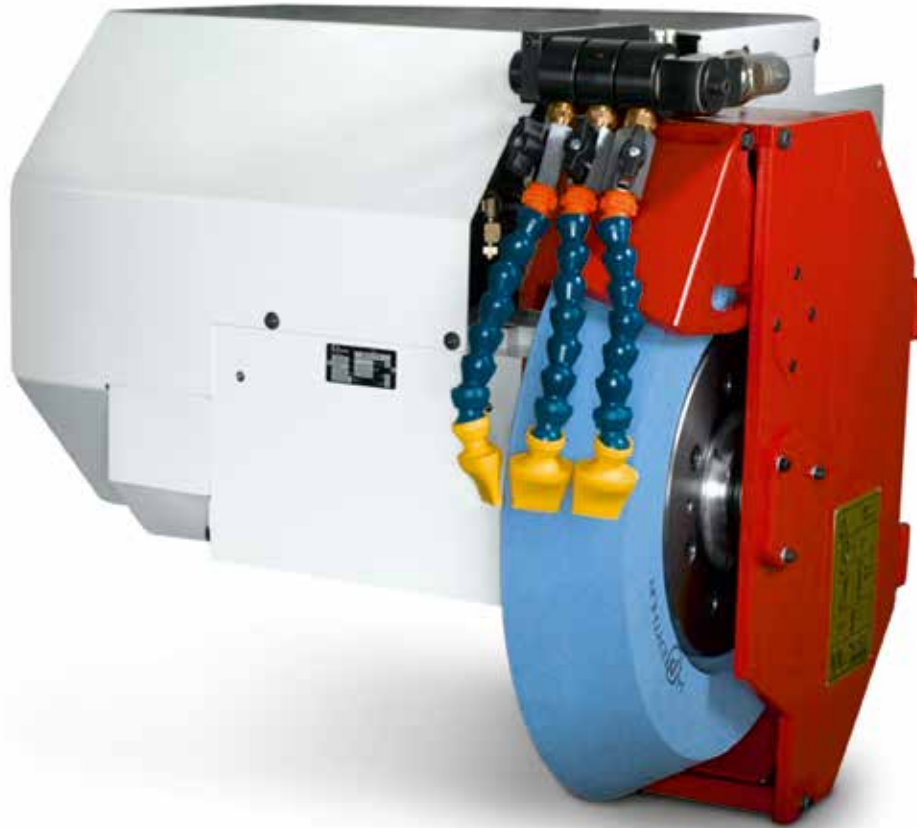

2



3

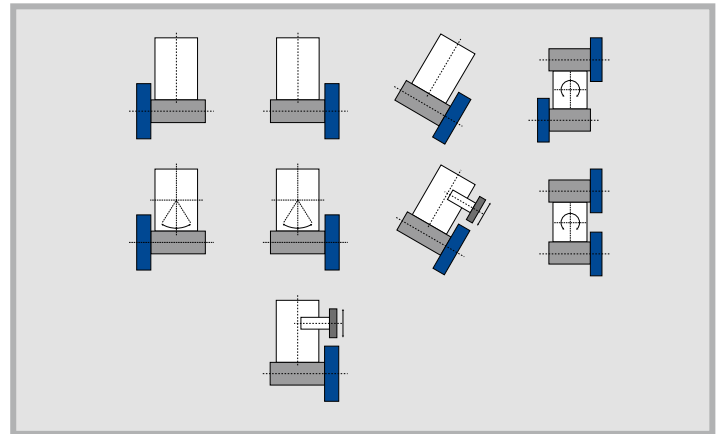

- Configurable according to client's requirements
- High performance
- Cutting speed up to 50 m/s (HSG 140 m/s)

The S22 platform has many different wheelhead variants. The machine can be optimally configured for any application. A swiveling unit with swiveling angle ± 9 deg for the right and the left wheel, is available for the 0 deg machine model. A turret wheelhead with wheel left/left resp. right/left rounds off the program.

Automatic A-axis

STUDER offers an automatically swiveling A-axis on the S22 for efficient, high-precision thread grinding. The swivel angle is ± 15 deg. Even greater pitch angles can be achieved with the aid of StuderThread, thanks to profile error compensation. There is one model for standard and one for highspeed grinding.

- 1 Wheelhead
- 2 Automatic A-axis
- 3 Examples for wheelhead configurations

Workhead



With its high-precision roller bearings the workhead is used for grinding between fixed centres and for live spindle grinding. The powerful workhead spindle has a MT4 or ISO50 fitting taper.

The airlift simplifies adjustment when setting up or resetting the workhead. The fine adjustment enables taper corrections in the μm -range during live spindle grinding.



- High roundness accuracy
- Low-maintenance

C-axis for form and thread grinding

Complete machining also entails form and thread grinding operations to an ever increasing extent. These processes are made possible by the position and speed-controlled C-axis. The standard C-axis with measuring system on the drive motor is suitable for thread grinding. To ensure the highest shape accuracy a direct measuring system is mounted on the workhead spindle (high-precision C-axis). Acceleration and grinding forces are absorbed without difficulty through the high dynamic rigidity of the axis drives

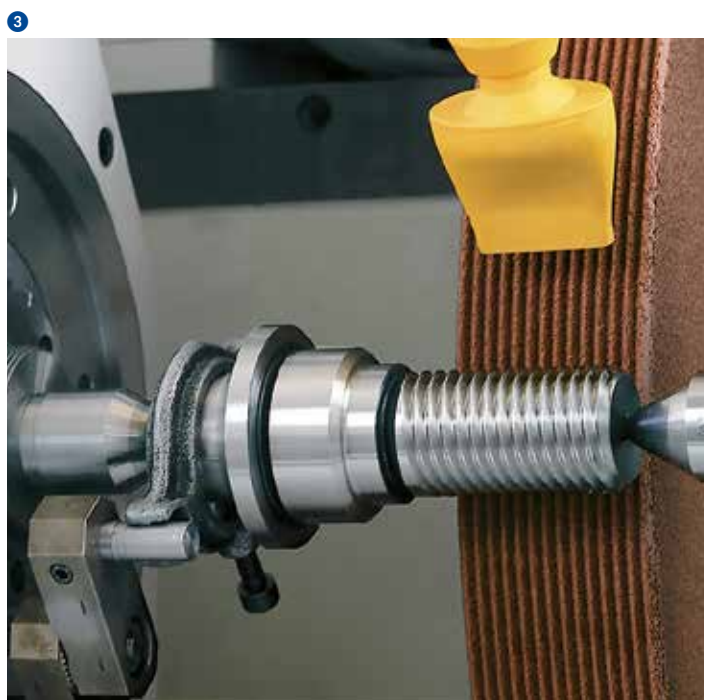

- 1 Chuck workhead
- 2 Fine adjustment for taper corrections
- 3 Thread grinding

Tailstock, synchronous tailstock

1



2



3



- Taper corrections
- Thermal stabilization via overflow capacity
- Synchronous tailstock

The rigid tailstock with generously dimensioned barrel is extremely stable and guarantees optimum grinding conditions for grinding between centres. The barrel slides in effectively covered floating bearings. The centre pressure can be adjusted simply and sensitively. The tailstock also has an air lift for quick and easy adjustment. In order to guarantee optimal thermal stability, the tailstock is flushed with coolant and both barrel and diamond holder are flooded.

Using of the synchronous tailstock is particularly cost-effective when manufacturing part families, when grinding a workpiece over its entire length or if attaching a driver is very costly. Thanks to the 90 mm barrel stroke, part families can be set up with minimal effort in very short times. This results in a considerable increase in productivity.

Dressing

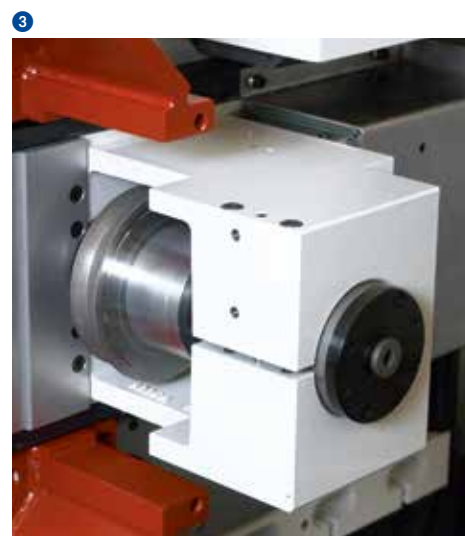
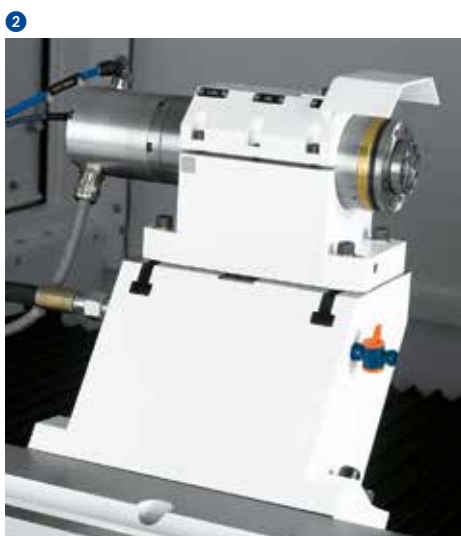

A sharp grinding wheel is essential for cost-effective, high-quality grinding. In order to create a flexible and optimal dressing process that coordinates with the properties of the workpiece, tool and materials, STUDER provides a large selection of dressing units. The grinding wheel profile and dressing parameters are easily defined via macros. Another STUDER speciality is the grinding wheel reference points (T-numbers). This enables programming with normal dimensions, which considerably facilitates the development of grinding programs.

A software package is available to fine tune the dressing process and includes additional dressing functions.

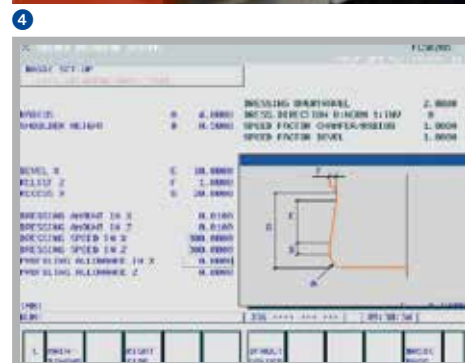

1 Diamond holder behind tailstock on table
2 Rotating dressing unit

3 Profile dressing unit
4 Dressing parameter screen

Operation and programming

1



2



- PCU manual control unit
- EMC-tested control cabinet
- Ergonomically arranged controls

The S22 is equipped with a Fanuc control system, series 31*i*-A. The clear and ergonomic arrangement of the control elements guarantees efficient operation.

The control cabinet can be positioned left, right or behind the machine, in accordance with the client's requirements. The power and control compartments are separated. The layout of the elements complies with the relevant safety norms and is EMC-tested.

StuderWIN

1

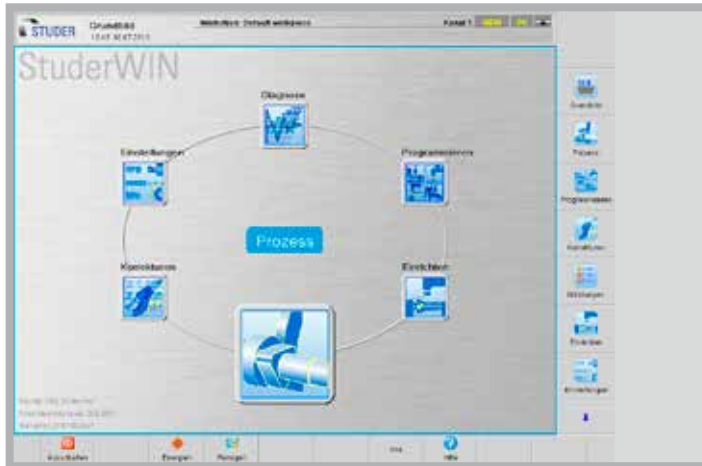

2

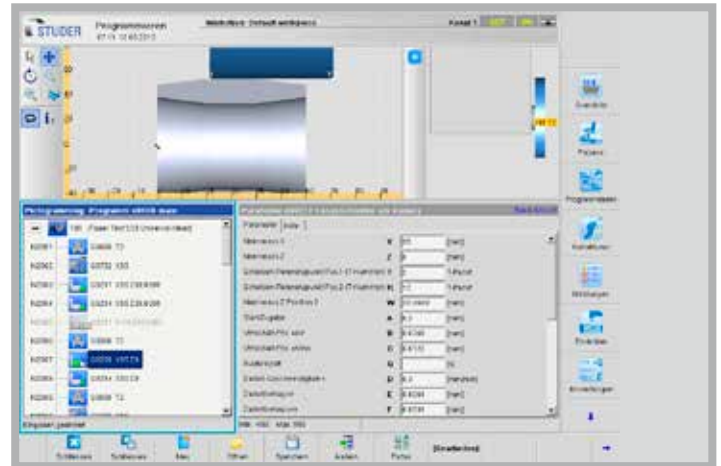

3

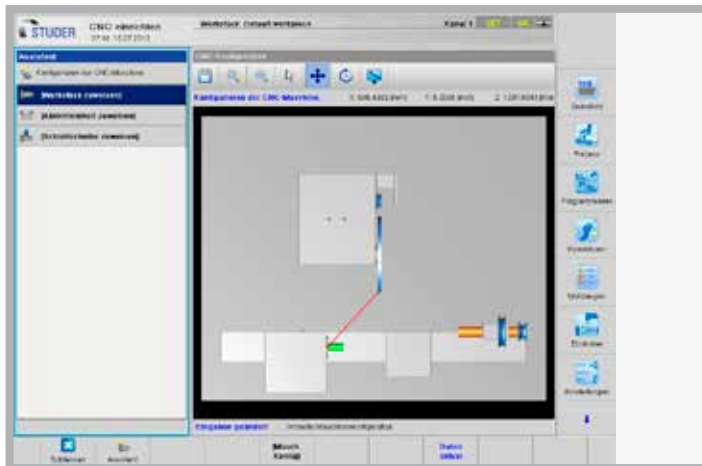

- Latest software technology
- StuderPictogramming
- Programming software StuderGRIND

StuderWIN as user interface and the software modules of StuderGRIND create a stable programming environment and contribute to the efficiency of the machine. A PC is integrated into the CNC control. The possibility of fully integrating the in-process gauging and sensor technology for process monitoring as well as contact detection and automatic balancing systems in the Windows control enable standardised programming of the different systems. The software for an internal loading system is also integrated in the control. The drive elements are optimally adapted to the control.

The sophisticated mechanical engineering concept of the S22 is completed by a grinding software program developed in-house by STUDER and continuously further optimized in collaboration with customers. This software offers:

- StuderPictogramming: The operator strings the individual grinding cycles together – the control unit generates the ISO code.
- STUDER Quick-Set: The software for grinding wheel alignment reduces changeover times by up to 90 %.
- Microfunctions: Free programming of grinding and dressing process sequences for optimization of the grinding process.
- StuderGRIND: Programming software for special applications such as form and thread grinding and profiling the grinding wheel for complex workpiece forms; the program is created on the PC and transferred directly to the machine control unit.

- 1 StuderWIN
- 2 Workpiece programming
- 3 Assisted Setup

Automation

①

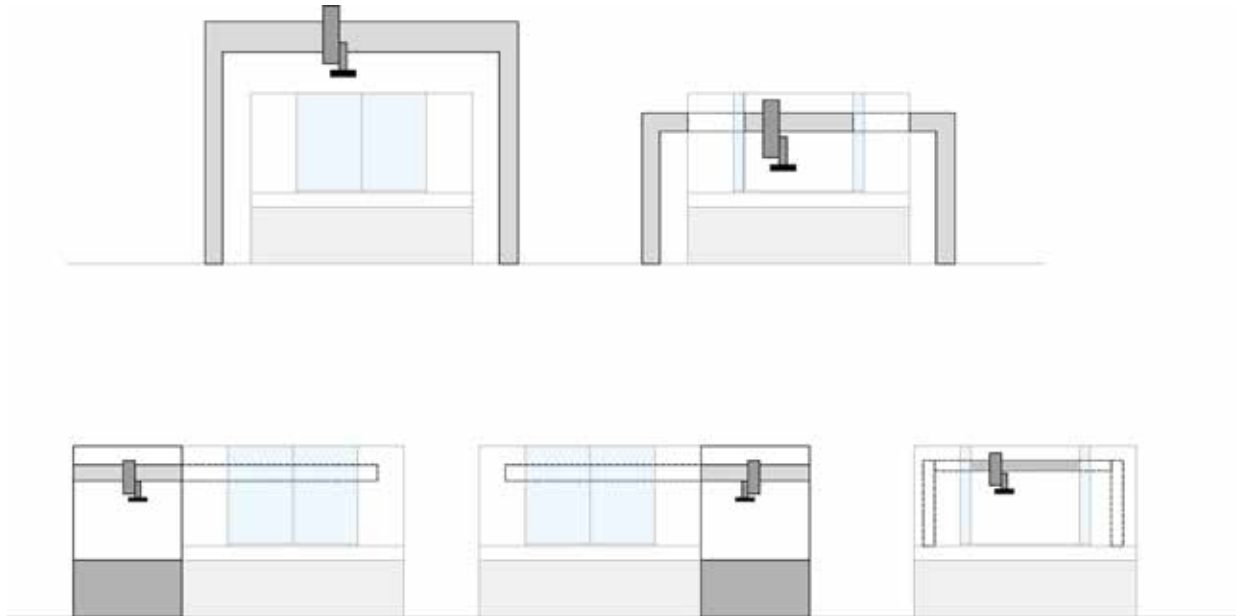

- Automated production processes
- Integrated quality control
- Standardized loading interfaces

The S22 is designed as a production grinding system. The selection of loading and unloading systems is accordingly large. The machine can be loaded from both sides and is excellently suited for linking several machines together.

The corresponding peripherals ensure seamless integration into the respective production process. The handling systems used communicate with the machine via the standardized loader interface and enable even complex handling tasks to be solved.

Comprehensive quality control is possible during the grinding process. This entails: in-process, and post-process measuring, recording, evaluation and correction.

The S22 has a compact design. Nevertheless, accessibility is guaranteed at all times. Large service doors on the left and right as well as movable front panels in the area of the workhead and tailstock facilitate the user's work and provide optimal possibilities for adapting automated loading systems. The electrical cabinet can be positioned as required by the customer. Coolant, pneumatic and hydraulic components are mounted at the back of the machine and are freely visible. A visual check can be carried out with a single glance.

Customer Care

STUDER cylindrical grinding machines should fulfil the customer's requirements for as long as possible, work cost-effectively, function reliably and be available at all times. From «start up» through to «retrofit» – our Customer Care is there for you throughout the working life of your machine. 30 professional helplines and more than 60 service technicians are available in your area, wherever you are in the world.

- We will provide you with fast, uncomplicated support.
- We will help to increase your productivity.
- We work professionally, reliably and transparently.
- We will provide a professional solution to your problems.



Start up

Commissioning
Warranty extension



Qualification

Training
Production support



Prevention

Maintenance
Inspection



Service

Customer service
Customer consultation
HelpLine
Remote service

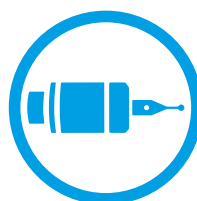

Material

Spare parts
Replacement parts
Accessories



Rebuild

Machine overhaul
Assembly overhaul



Retrofit

Modifications
Retrofits

Technical Data

Main dimensions

Distance between centres	650 mm (25.6") (machine-dependent – up to 1 100 mm (43.3" possible))
Grinding length	max. 800 mm (31.5")
Height of centres	175/225 mm (depending on options) (6.9"/8.9")
Max. workpiece weight	150 kg (330 lbs)

Cross-slides: X-axis

Max. travel	310 mm (12.2")
Speed	0,001 – 15 000 mm/min (0.000.04 – 590 ipm)
Resolution	0.00005 mm (0.000.002")

Longitudinal slide: Z-axis

Max. travel	850 mm (33.5")
Speed	0,001 – 30 000 mm/min (0.000.04 – 1 181 ipm)
Resolution	0.00005 mm (0.000.002")

Wheelhead

Motor spindle 12.5 kW

Plunge angle	0 deg or 30 deg
Swivel angle (option)	±9 deg
Driving power	12.5 kW (16.7 hp)
Grinding wheel left/right	dia. 500x80x203 mm (20" x 3.15" x 8")
Circumferential speed	up to 50 m/s (9840 sfpm)
Revolutions	1 400 – 3 200 rpm

Motor spindle 10.5 kW for high-speed grinding (option)

Plunge angle	0 deg or 30 deg
Swivel angle (option)	±9 deg or with B-axis
Driving power	10.5 kW (14 hp)
Grinding wheel left/right	dia. 400x40x127 mm (16" x 1.5" x 5")
Circumferential speed	up to 140 m/s (17 552 sfpm)
Revolutions	6 000 – 9 000 rpm

Belt-driven spindle 7.5 kW (hydrodynamic bearings)

Infeed angle	0 deg
Swivel angle (option)	±9 deg
Driving power	7.5 kW (10 hp)
Grinding wheel right	dia. 500x80x203 mm (20" x 3.15" x 8")
Circumferential speed	up to 50 m/s (9840 sfpm)
Revolutions	1 900 – 3 200 rpm

Belt-driven spindle 15 kW (mounted on roller bearings)

Plunge angle	0 or 15 or 30 deg
Driving power	15 kW (20.5 hp)
Grinding wheel right	dia. 610x160x304 mm (24" x 6.3" x 12")
Circumferential speed	up to 50 m/s (9840 sfpm)
Revolutions	1 600 – 2 330 rpm

Workhead spectrum

Speed range	1 – 1 500 rpm (workhead-dependent)
Drive power	1 – 4 kW (1.3 – 5.4 hp)
Roundness accuracy MT4	< 0,0004 mm (0.000.016")
Option	< 0,0002 mm (0.000.08")
C axis for form grinding	0,0001 deg

Tailstock

Fitting taper	MT3 (MT4)
Travel of barrel	35 mm (1.37") [60 mm (2.3")]
Barrel diameter	50 mm (1.97")
Fine adjustment	±40 µm (0.0016")

Synchronous tailstock

Fitting taper	MT4
Travel of barrel	90 mm (3.54")
Barrel diameter	50 mm (1.97")
Drive power	1,6 kW (2.2 hp)
Fine adjustment	±40 µm (0.0016")

Tailstock for fine grinding

Fitting taper	MT3
Travel of barrel	35 mm (1.37")
Barrel diameter	50 mm (1.97")
Fine adjustment	autom. ±40 µm (0.0016")

Control unit

Fanuc 31-A

Connected loads

Total connected loads	Max. 47 kVA
Air pressure	5,5 bar (80 psi)
Total weight	8 500 kg (18 700 lbs)

The information given is based on the technical levels of our machine at the time of this brochure going to print. We reserve the right to further develop our machines technically and make design modifications. This means that the dimensions, weights, colors, etc. of the machines supplied can differ. The diverse application possibilities of our machines depend on the technical equipment specifically requested by our customers. The equipment specifically agreed with the customer is therefore exclusively definitive for the equipping of the machines, and not any general data, information or illustrations.

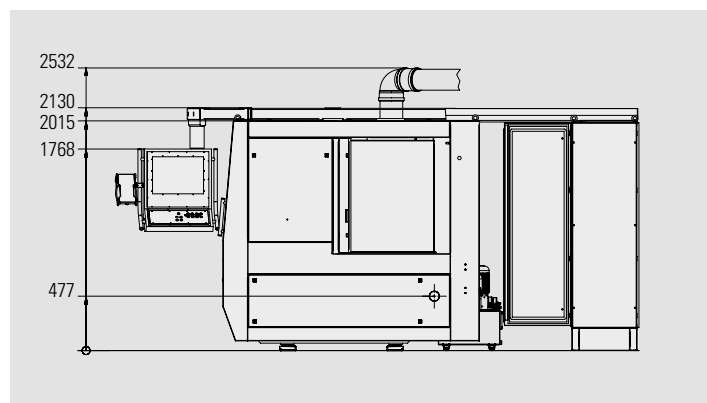
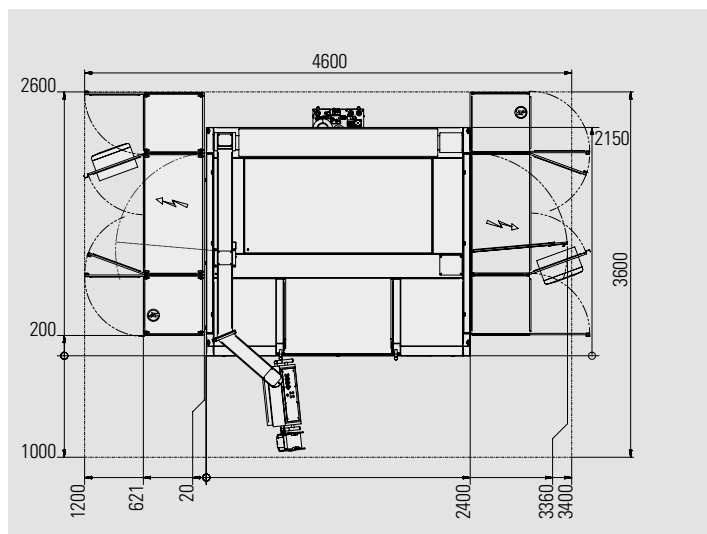
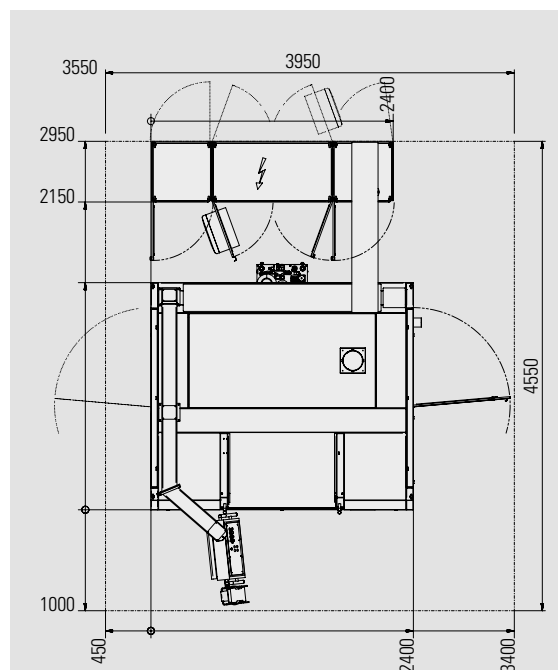



Fritz Studer AG
3602 Thun
Switzerland
Phone +41 33 439 11 11
Fax +41 33 439 11 12
info@studer.com
www.studer.com



ISO 9001
VDA6.4
certified

