

# FRYER

MACHINE SYSTEMS

Precision Built Solutions

# VERTICAL MACHINING



DESIGNED, ENGINEERED  
& ASSEMBLED IN USA

## MC-L SERIES

Linear Way High Speed Machining Centers

# **FRYER** MC-L SERIES



## **MC-24L/ MC-30L**

**24"/ 30"X 20"Y 20"Z**

**20" x 28"/ 35" Table Size**

**1,450 IPM Rapids**

**30 HP - 40 Taper Inline Spindle**

**60 - 10,000 RPM**

**30 Station Arm Style ATC**

# HIGH SPEED MACHINING CENTERS FOR PERFORMANCE AND RELIABILITY



## MC-40L

40"X 22"Y 22"Z

22" x 43" Table Size

1,450 IPM Rapids

30 HP - 40 Taper Inline Spindle

60 - 10,000 RPM

30 Station Arm Style ATC



DESIGNED, ENGINEERED  
& ASSEMBLED IN USA

# **FRYER** MC-L SERIES



## **MC-45L**

**45"X 25"Y 25"Z**  
**24" x 51" Table Size**  
**1,450 IPM Rapids**  
**30 HP - 40 Taper Spindle**  
**60 - 10,000 RPM**  
**30 Station Arm Style ATC**

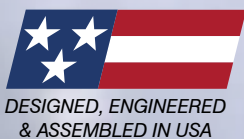

DESIGNED, ENGINEERED  
& ASSEMBLED IN USA

# HIGH SPEED MACHINING CENTERS FOR PERFORMANCE AND RELIABILITY



## **MC-60L**

**60"X 30"Y 28"Z  
24" x 67" Table Size  
1,450 IPM Rapids  
30 HP - 40 Taper Spindle  
60 - 10,000 RPM  
30 Station Arm Style ATC**

## INSIDE THE MC-L

### 10,000 RPM IN-LINE SPINDLE

CAT-40 Big Plus In-Line 10,000 RPM spindle is coupled directly to Siemens high torque spindle motor with 30 HP and 155ft/lbs. of torque. Optional 12K, 15K, 21K, 30K and BT Style.

### 30 STATION ARM STYLE ATC

High Speed arm style ATC is standard and can be upgraded to 40 or 60 tools.

### ALL AXES LASER CALIBRATED AND BALLBAR VERIFIED

Printed results of each are shipped with every machine.

### ROLLER TYPE LINEAR WAYS

High rigidity with higher cutting speeds and rapid rates as well as more accurate positioning.



# WHY WE'RE BUILT BETTER

## ABSOLUTE ENCODERS

Remembers your position with the power off. All fixture offsets and tool offsets are maintained so you don't have to re-indicate parts like on other controls.

## FRYER / SIEMENS 828-HS CONTROL

The ultimate production CNC. Easy to use for single piece jobs or production runs but includes features unmatched by any other builder. Regenerative drives save you over 40% on electricity.

## PRECISION GROUND C3 GRADE DOUBLE NUT BALLSCREWS

Provides incredible 0.0002" accuracy for your most demanding jobs.

## AUTOMATIC GREASE LUBRICATION SYSTEM

Auto grease system provides better lubrication of ways and ballscrews and will not contaminate coolant.

# MANUAL OPERATION

## THE FRYER / SIEMENS 828-HS

The Fryer / Siemens 828-HS offers the flexibility to run the machine manually when needed. All the ShopMill conversational cycles that are used in a program are available in manual mode to run as a do-one operation. Axis jog buttons and do one positioning let you position your tool, turn on the spindle and make your cut. No knowledge of G code is needed.

## HANDWHEEL/HANDWHEEL RUN

Axis and resolution select as well as Cycle Start and Feed hold Buttons allows for easy manual positioning of tools or table. You can also run the program with the available Handwheel Run feature.

## ELECTRONIC STOPS

Allows you to set a stop position for any axis. Turn the handwheel or axis push buttons and you can't move past the stop position.



## NEXT TOOL/PREVIOUS TOOL

Easy tool changes without commands using next tool/previous tool buttons.

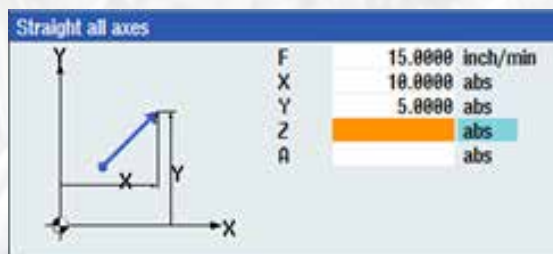

## PUSHBUTTON POSITIONING

Move one axis or all at once with a controlled feed rate or in rapid. Positioning moves can be made in absolute or incremental.



## OTHER MANUAL FEATURES

- **MANUAL SPINDLE CONTROL** Enter the RPM and spindle direction and push cycle start
- **JOG BUTTONS** Select the axis and adjust the feed rate override dial to your desired feed rate
- **TEACH MODE** Records positions with a push of a button as you move X Y and Z around. Can then be used to create a program or run by itself.



## TAPERS AND CHAMFERS

Set the angle required and by turning the handwheel both axes move at the desired angle.



# NO CNC EXPERIENCE NEEDED

## DO ONE CYCLES

The Do One cycles allow you to quickly drill, bore or tap holes automatically by filling out a simple screen. Once the operation is completed the machines returns to manual mode. Includes pocket cycles, thread milling, drilling, boring, rigid tap, engraving and keyway slots.

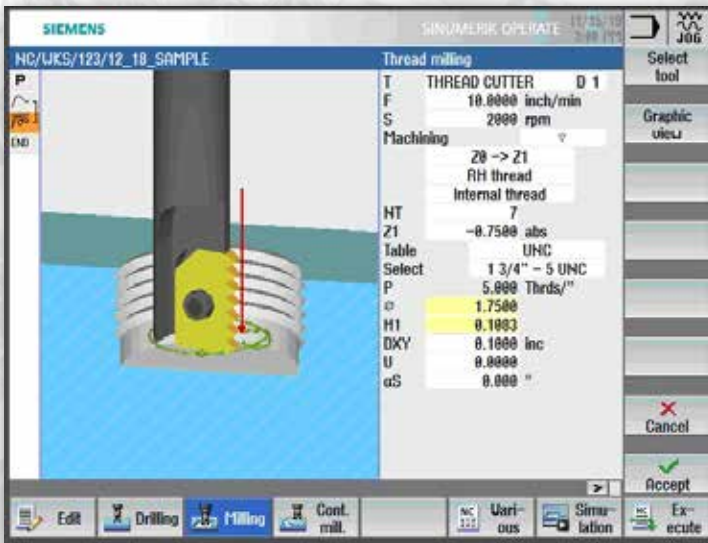

## THREAD MILLING

What is usually a tricky programming operation becomes a simple fill in one box procedure. The Thread Mill cycle can run by itself in Manual Mode without having to write an entire program. External/internal threads, inch/metric, right hand/left hand threads are all there in the same do-one cycle.

## POCKETING

You just need to make one quick pocket so why write an entire program? In Manual Mode all machining cycles are available to run by themselves with no program required. You choose your tool, speeds and feeds, pocket size, depth and how you want your tool to enter the material. The cycle does the rest.

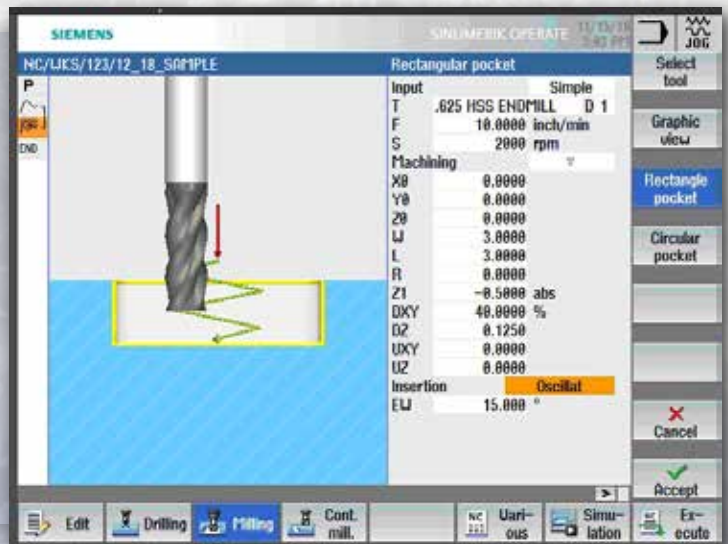

# PROGRAMMING

## DRILLING CYCLES

Several drill cycles are available, chip breaking, chip removal, center drilling, reaming etc. All canned cycles retain the last numbers entered saving you time and money.

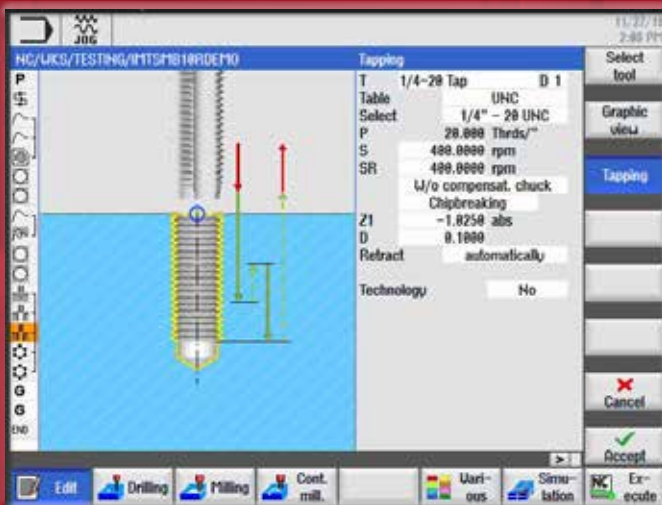
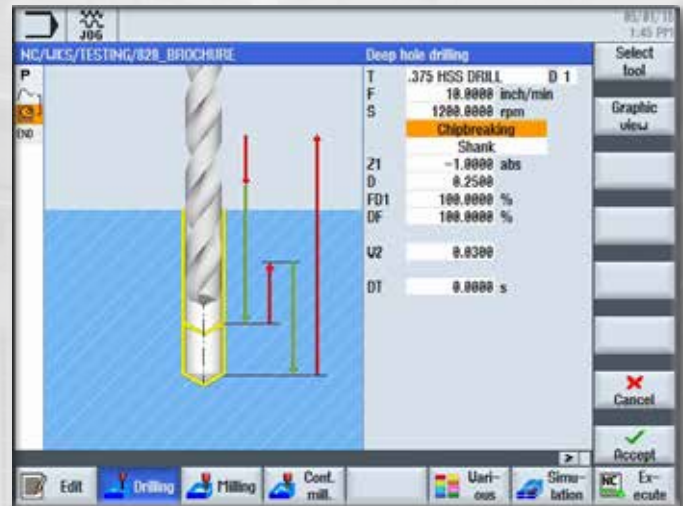

## TAPPING CYCLE

This cycle has several tap forms in inch and metric pre-defined. Tough material? Select Chipbreaking or Chip Removal. Enter the RPM and the control automatically calculates the feed rate.

## CONTOUR EDITOR

The Contour Editor lets you create simple or complex tool paths. As you enter dimensions the path is visually generated. Don't know an end point? The editor will fill-in missing points.

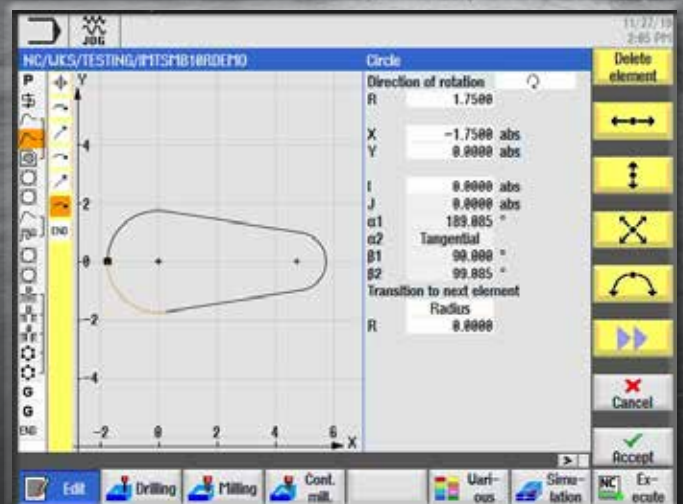

# FROM DRAWING TO FINISHED PART

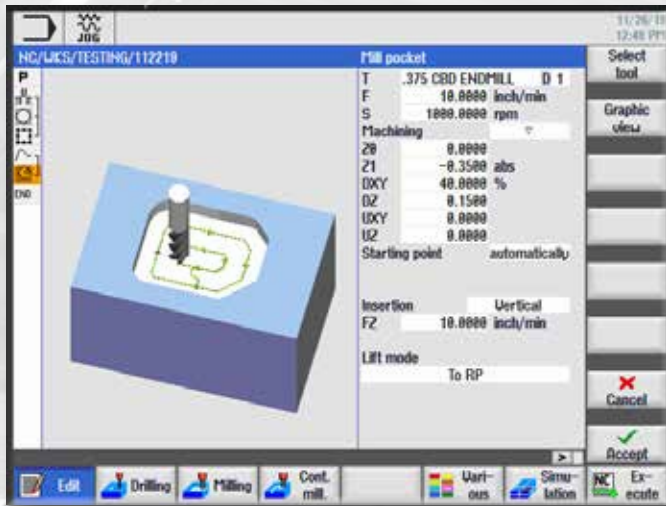

## MACHINING THE CONTOUR

Once the contour is created you link to a cycle to machine it. Pocketing, Path Milling or Spigot all let you control how you want to machine the part. This cycle has a finishing operation and can also chamfer the edge of the part.

## G CODE PROGRAMMING

The Fryer / Siemens 828-HS also offers standard part programming in either Siemens G Code or emulated ISO/Fanuc mode. Programs posted from CAM systems can also be simulated before running. Full editing, renumbering as well as find and replace are included.

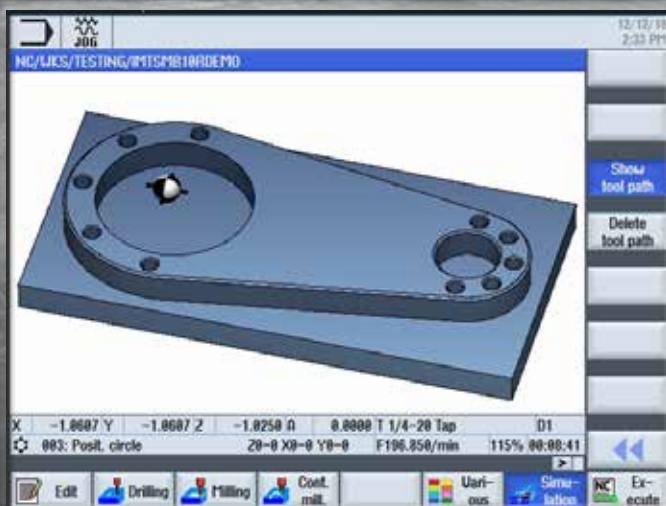
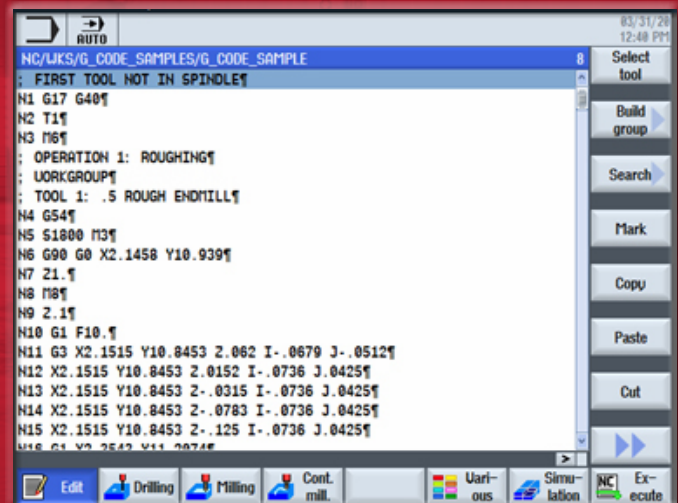

## SIMULATION MODE

Before making any chips the full featured simulation mode lets you see the part in 3D to check if everything is correct compared to the print. Part can be rotated, zoomed and cut to see into different areas of the part. Hole in the wrong place? Fix it before you actually machine it. Simulation even shows cycle time.

**FRYER**

# SETUP AND OPERATION



## TOOL TABLE

Graphic display shows the type and name of the tool. You can also control spindle direction and coolant. Tool life monitoring is also standard for time in cut or part count.

## AUTOMATIC TOOL & PART PROBES

Wireless Renishaw or Marposs tool probes automatically set your tool length and diameter offsets.



## PART PROBING/ MEASURING CYCLES

Several standard cycles are available to find centers of holes, part edges, and bosses. Cycles can also be used to measure finished parts and display the reading.



## DEFINE TOOLS

The tool page is where tools are created. The 828-HS gives you an extensive library of tools to pick from. When naming tools you have the option of giving tools a number or a description of what they actually are. After you create the tool it shows a visual display of the tool. Multiple edges, tool wear adjustments and tool life monitoring are all standard.



# FASTER, SIMPLER & MORE PRODUCTIVE

## SET PART ZERO

Several standard cycles are available to set part Zero. They can be used with a conventional edge finder or an automatic part probe. These cycles can also be used to measure the part and display the values before removing it from the machine, much like a built-in CMM.



## SET TOOL LENGTH OFFSETS

Once the tools are created they are set either manually off the part or automatically with a tool probe. Standard tool measuring cycles set the length, and depending on the probe used, the tool diameter.

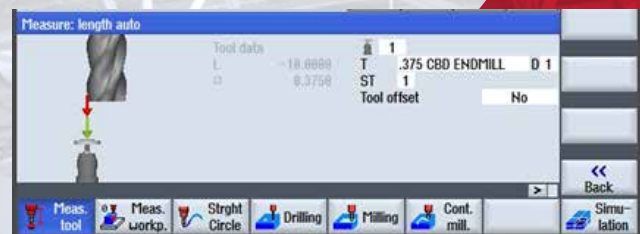

## HANDWHEEL RUN

This feature allows you to control your program execution with the optional electronic handwheel. Turning the handwheel causes the program to run with you in charge of the axis feed. Turn it slow or speed things up by cranking faster. When you stop turning the axes stop moving, turn the handle the opposite direction and the axes move backwards though the program. Designed to make proving-out programs easier with safety and confidence. (optional)

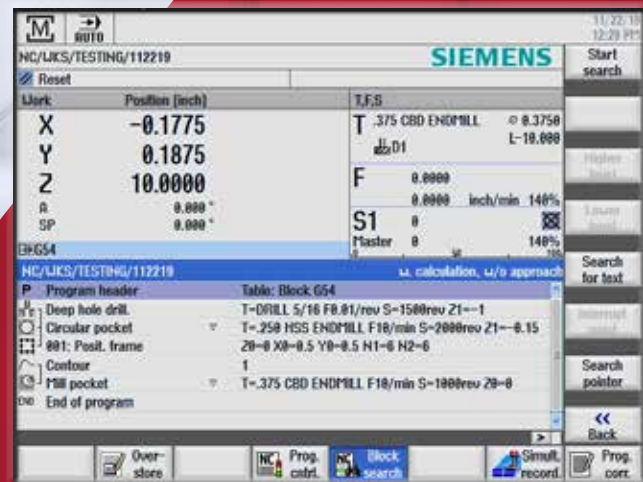

## RUN PROGRAM

After the program is proved out in simulation you are ready to run. The Auto screen Block Search function lets you start anywhere in the program. Part counters and run times are also included.

**FRYER**

# CONTROL OPTIONS

## IN-PROCESS PROBE MEASUREMENT CYCLES

This feature allows you to measure part features during program execution. Can also be used in MDI mode after cutting the part to then measure certain features and display the measurement.

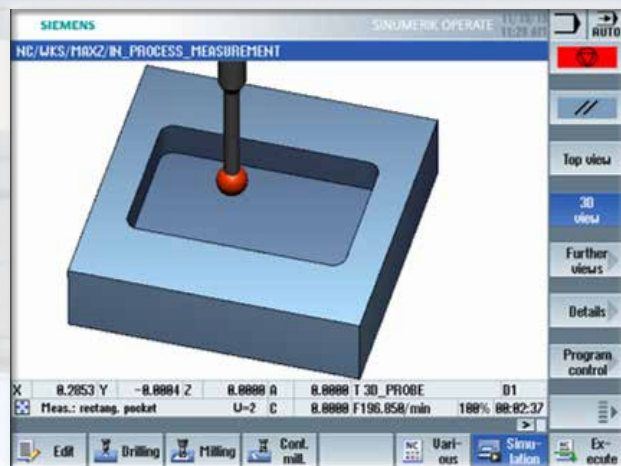

## COLLISION AVOIDANCE - REAL-TIME, 3D PROTECTION MONITORING PROTECTION YOU CAN USE

828-HS Collision Avoidance provides protection by monitoring the static machine tool components in 3D and in real-time. Works in every operating mode including Jog, MDI and Automatic. With Collision Avoidance, the potential for machine components colliding is greatly reduced or even eliminated, making the process more cost-efficient.

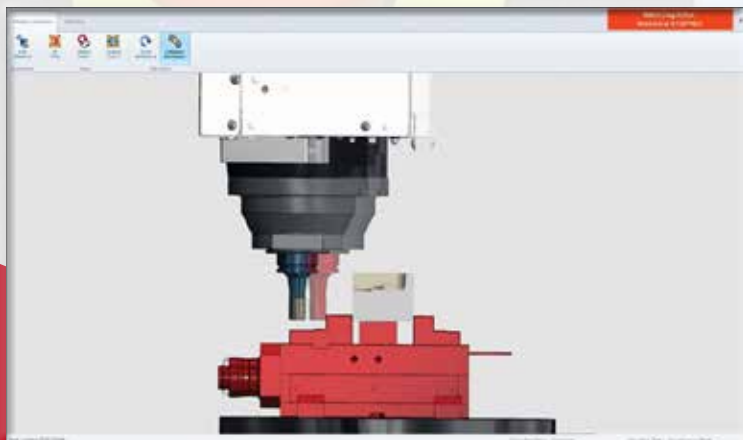

## DXF FILE IMPORT FEATURE

Allows you to import DXF files and quickly convert to a conversational program. Automatically create points for drilling operations or contours for milling.

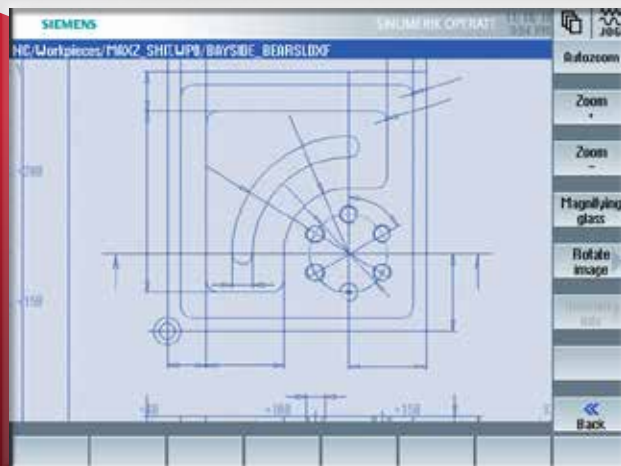

## 3D HIGH SPEED MACHINING

Features high speed 1.5ms block processing and 500 block look-ahead. Advance Surface features jerk control and nano smoothing with a compressor mode which determines optimal velocity for programs containing circular and linear blocks. High speed roughing parameters and lower speed finishing parameters provide incredible surface finish at lowest possible cutting time.

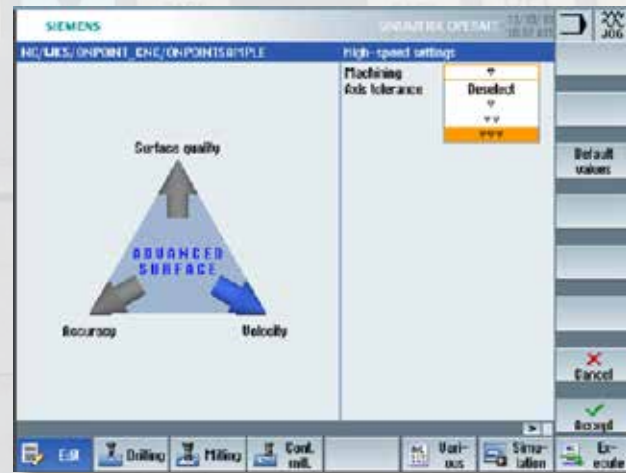

## 4TH AXIS SURFACE CYCLES

Allows programming of XYZ coordinates and cycles like pockets and engraving. These are then automatically projected onto a cylindrical surface. For use with 4th axis rotary tables.



## ADAPTIVE FEED CONTROL

The Adaptive Feed Control cycle monitors the spindle load and varies the feed rate accordingly. By entering the maximum spindle load and then entering a range of minimum and maximum feedrate override values, the control monitors these settings and adjusts the feeds automatically. When approaching corners and radii the feed rate will slow down, during straight line moves the feedrate increases to shorten the cutting time and help produce more parts per hour.

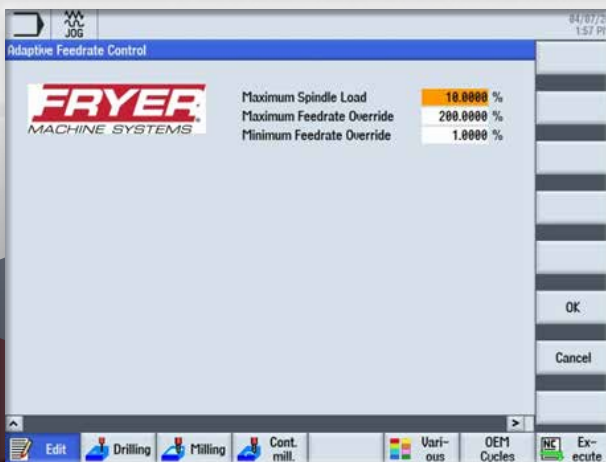

# MACHINE OPTIONS

## HIGH PRESSURE COOLANT THROUGH THE SPINDLE SYSTEM

Available in either 350 or 1000 PSI. Includes adjustable high volume 8 gallon / minute pump. Allows full pressure even with tool coolant holes up to .100" diameter. System includes 10-micron replaceable filter cartridge.



## SPINDLE OPTIONS

Many spindle options available: 12K, 15K, 21K and 30K RPM's and BT style.

## ADDITIONAL OPTIONS

- Cabinet A/C Unit
- Extended Y and Z travels
- 40HP spindle motor upgrade
- Tooling packages



40 TOOL ATC UPGRADES



## 4TH AXIS ROTARY TABLES & 5TH AXIS TRUNNIONS

Fryer made 4th and 5th axis rotary tables and trunnions are perfect for multisided machining. Ultra-precise ring and worm gear set ensure accuracy. All tables feature full support for heavy duty cutting and hydraulic disc brake. Many different table sizes and configurations available.

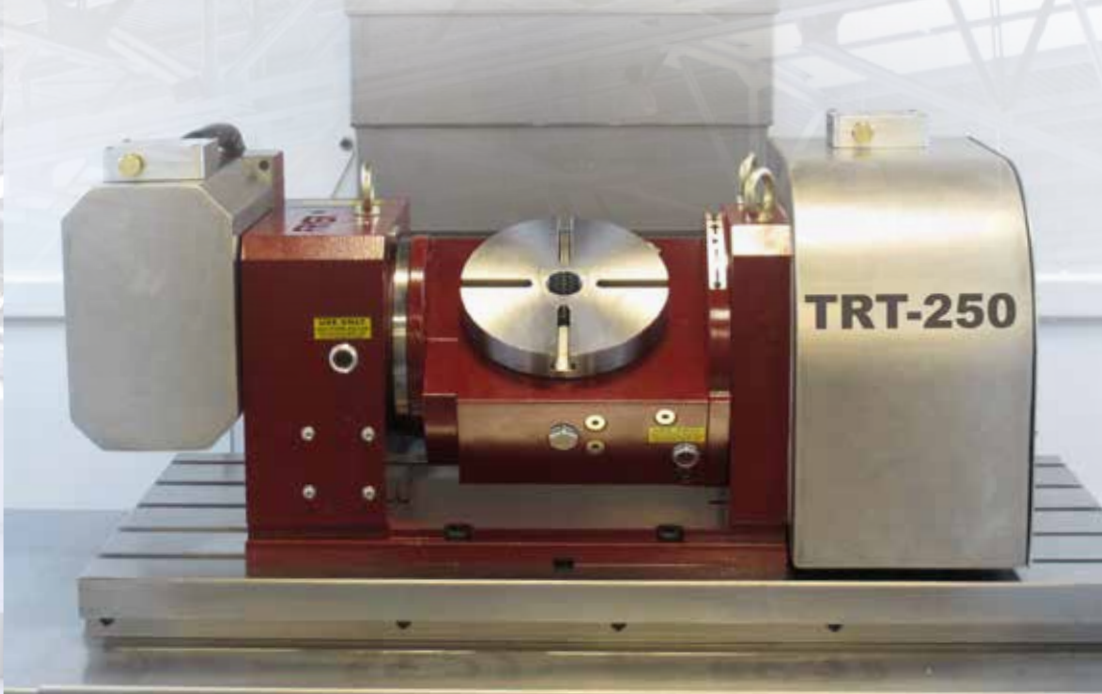

## HEIDENHAIN GLASS SCALES

This is a super accurate system using dual feedback. The standard encoders provide a stable servo loop while the ultra-precision scales provide final position accuracy.



**FRYER**

# MACHINE OPTIONS



## CHIP CONVEYORS AND CHIP AUGERS

Fryer offers both chip augers and chip conveyors custom fit to the machine. An available washdown system washes chips down into the trough. A separate washdown hose is also included.

## ABRASIVE MATERIAL MACHINING PACKAGE

This package includes one piece steel and accordion type sealed way covers that protect the ways from abrasive contaminants. Also includes a sealed electrical cabinet with a high efficiency heat exchanger.





## **FRYER / SIEMENS ADVANCED 2300 CONTROL**

The Fryer / Siemens Touch 2300 CNC provides world class technology and ultra-advanced features in an intuitive user interface. Based on the powerful Siemens 840D SL, this state of the art platform provides the ultimate for 5 axis and high speed machining. 19" touch screen features a high-resolution, digital color monitor with finger motions to control pinch, zoom and scroll. Shop floor programming, G code programming, large program storage, Ethernet connectivity, 3D solid model graphic verification speed the first article process.

## **FANUC 0I-F AND 30I-B SERIES CONTROLS**

Industry standard FANUC controls are available on all Fryer machines. The 0i series Model F features up to 4 axis simultaneous capability and the 30i series Model B for complex 5 axis capability and beyond. All FANUC controls include matching digital drives and axis servo motors as well as powerful FANUC spindle motors. Many control options available such as AI Contour Control, High Speed Machining and Nano Interpolation allow custom configurations.



**FRYER**

MC-L SERIES SPECIFICATIONS		MC-24L	MC-30L	MC-40L	MC-45L	MC-60L
MACHINE CAPACITY	X Travel	24"	30"	40"	45"	60"
	Y Travel	20"	20"	22"	25"	30" (35")
	Z Travel	20"	20"	22"	25"	28" (38")
	Ballscrew size	1.57"	1.57"	1.57"	1.57"	1.57"
	Table Load (Evenly Distributed)	2,000 lbs.	2,500 lbs.	3,000 lbs.	3,500 lbs.	4,500 lbs.
	Table Size	20" x 28"	20" x 35"	22" x 43"	24" x 51"	24" x 87"
	T-Slots (No./Width)	5 / .708"	5 / .708"	5 / .708"	5 / .708"	5 / .708"
Table Top to Floor	28"	28"	30"	32"	32"	
SPINDLE	Motor HP (Peak)	30.0 HP				
	Spindle Speed (RPM)	60 - 10,000 RPM (12K, 15K, 21K, 30K Optional)				
	Spindle Torque (max)	155 ft/lbs @ 350 RPM				
	Tool Type/Taper	Big Plus CAT 40 (BT Option)				
	Spindle Nose to Table (Max - Min)	24" - 4"	24" - 4"	26" - 4"	29" - 4"	32" (42") - 4"
	Spindle Center to Column	21"	21"	23"	26"	31"
ATC	Tool Storage Capacity	30 Station High Speed Arm Type (40 Option)				
	Tool Change Time	1.5 Seconds				
	Max. Tool Diameter (full)	3.2"				
	Max. Tool Dia. (adjacent empty)	5.9"				
	Max. Tool Weight	15.4 lbs.				
	Max. Tool Length	13"				
PERFORMANCE	Positioning Accuracy X, Y, Z	+/- 0.0002"				
	Positioning Repeatability X, Y, Z	+/- 0.0001"				
	Resolution	0.0001"				
	Rapid Traverse	1,450 X, Y, Z	1,450 X, Y, Z	1,450 X, Y, Z	1200 X, Y, Z	1200 X, Y, Z
	Cutting Feed Rate	.001 - 1,200 IPM				
	Servo Type	AC Digital Brushless				
Axis Thrust (Peak)	4,000 lbs. X, Y, Z					
GENERAL INFO	Air Pressure Requirements	90 PSI - 5 CFM				
	Coolant Capacity	90 Gallons				
	Coolant Flow	9 Gal/Min				
	Door Open Width	28"	32"	42"	47"	62"
	Power Requirements	40 AMP 380-500 VAC 3 PHASE (205-245 VAC Optional)				
	Shipping Dimensions* (WxDxH)	83"x76"x72"	93"x86"x76"	99"x86"x88"	127"x87"x87"	161"x89"x93"
	Operating Dimensions (WxDxH)	83"x76"x85"	93"x86"x89"	111"x86"x110"	127"x104"x110"	161"x112"x112"
Machine Weight	7,900 lbs.	8,400 lbs.	9,500 lbs.	14,500 lbs.	20,000 lbs.	

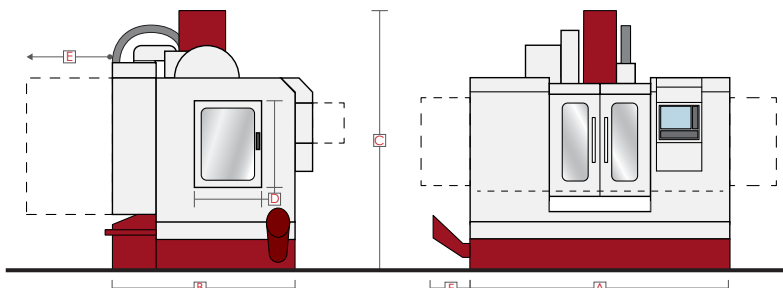

	MC-24L	MC-30L	MC-40L	MC-45L	MC-60L
Floor Width (A)	93"	93"	111"	127"	161"
Floor Depth (B)	86"	86"	86"	104"	112"
Maximum Height (C)	89"	89"	110"	110"	112"
Side Door - Width x Height (D)	28.5 x 36.5"	28.5 x 36.5"	27 x 34"	30 x 30"	47 x 32"
Electrical Cabinet Swing (E)	34"	34"	34"	38"	38"
Protrusion (Auger/Conveyor) (F)	20"	20"	20"	16"	20"/48"
Appropriate Machine Weight	7,900 lbs.	8,400 lbs.	9,500 lbs.	14,500 lbs.	20,000 lbs.

\* Requires some disassembly to meet these minimum dimensions. Contact factory for more information.

© 2020 Fryer Machine Systems, Inc. rev 081520  
Specifications subject to change without prior notice.